



User Guide

SM-Universal Encoder Plus

Solutions module for
Unidrive SP

Part Number: 0471-0005-06

Issue Number: 6

Version: 04.xx.xx

General Information

The manufacturer accepts no liability for any consequences resulting from inappropriate, negligent or incorrect installation or adjustment of the optional operating parameters of the equipment or from mismatching the variable speed drive with the motor.

The contents of this guide are believed to be correct at the time of printing. In the interests of a commitment to a policy of continuous development and improvement, the manufacturer reserves the right to change the specification of the product or its performance, or the contents of this guide, without notice.

All rights reserved. No parts of this guide may be reproduced or transmitted in any form or by any means, electrical or mechanical including photocopying, recording or by an information storage or retrieval system, without permission in writing from the publisher.

Drive software version

The SM-Universal Encoder Plus can only be used with drive software version 00.11.00 onwards.

Some features of the SM-Universal Encoder Plus may not be available if the drive software is not the latest version (01.07.00)

Option module software version

The issue 4 SM-Universal Encoder Plus option module must only be programmed with software versions 04.xx.xx.

Failure to comply with this will result in module failure.

Contents

1	How to use this guide	5
1.1	Intended personnel	5
1.2	Information	5
2	Safety Information	6
2.1	Warnings, Cautions and Notes	6
2.2	Electrical safety - general warning	6
2.3	System design and safety of personnel	6
2.4	Environmental limits	7
2.5	Compliance with regulations	7
2.6	Motor	7
2.7	Adjusting parameters	7
3	Introduction	8
3.1	Features	8
3.2	Solutions Module identification	8
3.3	Set-up parameters	9
3.4	Compatible with encoder types	9
4	Encoder feedback selection	18
4.1	Encoder selection	18
4.2	Considerations	20
4.3	Drive resolution / Feedback accuracy	22
5	Installing the SM-Universal Encoder Plus	24
5.1	Solutions Module slots	24
5.2	Installation	24
5.3	Terminal descriptions	26
5.4	Power supply	28
5.5	Encoder shield connections	28
5.6	Grounding hardware	29
6	Getting Started	37
6.1	Installation	37
6.2	Termination resistors	44
6.3	Simulated encoder outputs	45
6.4	Marker inputs	51
6.5	Marker outputs	51
6.6	Freeze inputs	52
6.7	Thermistor input	55
7	Encoder feedback positional information	56
7.1	Encoder feedback positional information	56
8	Advanced Operation	58
8.1	Serial communications	58
8.2	Electronic nameplate transfers	66

9	Parameters	70
9.1	Introduction	70
9.2	Single line descriptions	71
9.3	Parameter descriptions	76
10	Diagnostics	98
10.1	Display	98
10.2	Displaying the trip history	99
10.3	Fault finding	103
11	Terminal Data	104
11.1	Encoder inputs SK2	104
11.2	Simulated encoder outputs SK2	105
11.3	Drive encoder power supply	106
11.4	Encoder inputs PL1	107
11.5	Encoder outputs PL1	107

1 How to use this guide

1.1 Intended personnel

This guide is intended for personnel who have the necessary training and experience in system design, installation, commissioning and maintenance.

1.2 Information

This guide contains information covering the identification of the Solutions Module, terminal layout for installation, fitting of the Solutions Module to the drive, parameter details and diagnosis information. Additional to the aforementioned are the specifications of the Solutions Module.

2 Safety Information

2.1 Warnings, Cautions and Notes



A **Warning** contains information, which is essential for avoiding a safety hazard.



A **Caution** contains information, which is necessary for avoiding a risk of damage to the product or other equipment.

NOTE

A **Note** contains information, which helps to ensure correct operation of the product.

2.2 Electrical safety - general warning

The voltages used in the drive can cause severe electrical shock and/or burns, and could be lethal. Extreme care is necessary at all times when working with or adjacent to the drive.

Specific warnings are given at the relevant places in this User Guide.

2.3 System design and safety of personnel

The drive is intended as a component for professional incorporation into complete equipment or a system. If installed incorrectly, the drive may present a safety hazard.

The drive uses high voltages and currents, carries a high level of stored electrical energy, and is used to control equipment which can cause injury.

Close attention is required to the electrical installation and the system design to avoid hazards either in normal operation or in the event of equipment malfunction. System design, installation, commissioning and maintenance must be carried out by personnel who have the necessary training and experience. They must read this safety information and this User Guide carefully.

The STOP and SECURE DISABLE functions of the drive do not isolate dangerous voltages from the output of the drive or from any external option unit. The supply must be disconnected by an approved electrical isolation device before gaining access to the electrical connections.

With the sole exception of the SECURE DISABLE function, none of the drive functions must be used to ensure safety of personnel, i.e. they must not be used for safety-related functions.

Careful consideration must be given to the functions of the drive which might result in a hazard, either through their intended behaviour or through incorrect operation due to a fault. In any application where a malfunction of the drive or its control system could lead to or allow damage, loss or injury, a risk analysis must be carried out, and where necessary, further measures taken to reduce the risk - for example, an over-speed protection device in case of failure of the speed control, or a fail-safe mechanical brake in case of loss of motor braking.

The SECURE DISABLE function has been approved¹ as meeting the requirements of EN954-1 category 3 for the prevention of unexpected starting of the drive. It may be used in a safety-related application. **The system designer is responsible for ensuring that the complete system is safe and designed correctly according to the relevant safety standards.**

¹Independent approval by BIA has been given for sizes 1 to 5.

2.4 Environmental limits

Instructions in the *Unidrive SP User Guide* regarding transport, storage, installation and use of the drive must be complied with, including the specified environmental limits. Drives must not be subjected to excessive physical force.

2.5 Compliance with regulations

The installer is responsible for complying with all relevant regulations, such as national wiring regulations, accident prevention regulations and electromagnetic compatibility (EMC) regulations. Particular attention must be given to the cross-sectional areas of conductors, the selection of fuses or other protection, and protective earth (ground) connections.

The *Unidrive SP User Guide* contains instruction for achieving compliance with specific EMC standards.

Within the European Union, all machinery in which this product is used must comply with the following directives:

98/37/EC: Safety of machinery.

89/336/EEC: Electromagnetic Compatibility.

2.6 Motor

Ensure the motor is installed in accordance with the manufacturer's recommendations. Ensure the motor shaft is not exposed.

Standard squirrel cage induction motors are designed for single speed operation. If it is intended to use the capability of the drive to run a motor at speeds above its designed maximum, it is strongly recommended that the manufacturer is consulted first.

Low speeds may cause the motor to overheat because the cooling fan becomes less effective. The motor should be fitted with a protection thermistor. If necessary, an electric forced vent fan should be used.

The values of the motor parameters set in the drive affect the protection of the motor. The default values in the drive should not be relied upon.

It is essential that the correct value is entered in parameter **0.46** (Pr **5.09**) motor rated current. This affects the thermal protection of the motor.

2.7 Adjusting parameters

Some parameters have a profound effect on the operation of the drive. They must not be altered without careful consideration of the impact on the controlled system.

Measures must be taken to prevent unwanted changes due to error or tampering.

3 Introduction

3.1 Features

The SM-Universal Encoder Plus allows for various types of feedback device to be connected to the Unidrive SP, and to be configured for either reference or main feedback. The SM-Universal Encoder Plus also has a simulated encoder output which can be programmed to operate in either Ab, Fd or SSI mode (software simulation). Or alternatively use a hardware simulated encoder output from either the modules encoder input or the drives main encoder input. No scaling is possible with the hardware simulated encoder outputs.

A total of three Solutions Modules can be fitted to the drive at any one time, with these being used for position and speed feedback. See Figure 5-1 *Location of slots 1, 2 and 3 on the Unidrive SP* on page 24

Figure 3-1 SM-Universal Encoder Plus

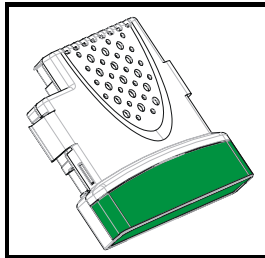
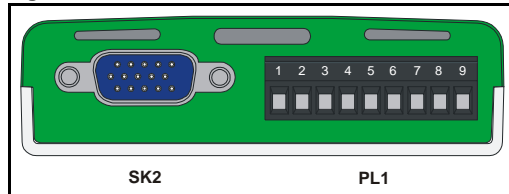

Figure 3-2 SM-Universal Encoder Plus connectors



3.2 Solutions Module identification

The SM-Universal Encoder Plus can be identified by:

1. The label located on the underside of the Solutions Module.
2. The colour coding across the front of the Solutions Module. All Unidrive SP Solutions Modules are colour coded, with the SM-Universal Encoder Plus being light green.
3. The packaging label which identifies the module as either an issue 3 or issue 4 module e.g (firmware **V04.xx.xx** being an issue 4 module).
4. Pr **x.02** e.g (**04.xx**) being an issue 4 module (Pr **x.02** where x refers to either menu 15, 16 or 17 as detailed in section 4.1).

Figure 3-3 SM-Universal Encoder Plus label

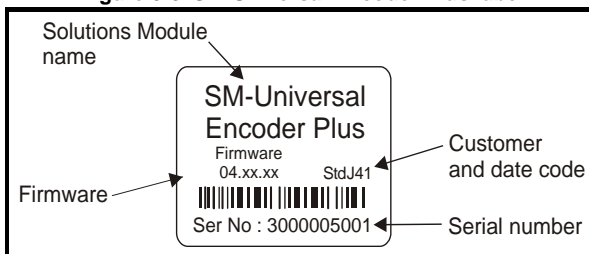

3.2.1 Date code format

The date code is split into two sections: a letter followed by a number.

The letter indicates the year, and the number indicates the week number (within the year) in which the Solutions Module was built.

The letters go in alphabetical order, starting with A in 1990 (B in 1991, C in 1992 etc.).

Example:

A date code of L35 would correspond to week 35 of year 2002.

3.3 Set-up parameters

All parameters associated to the SM-Universal Encoder Plus can be found in either menu 15, 16, or 17. Each of menus 15, 16, and 17 refer to one of the available slots into which the SM-Universal Encoder Plus can be fitted. See Figure 5-1 on page 24.

3.4 Compatible with encoder types

The SM-Universal Encoder Plus will allow for the following encoders to be used with Unidrive SP:

3.4.1 Incremental encoders Ab, Fd, Fr and SC

These types of encoders give incremental position and can only be used for control in Closed Loop Vector mode, or alternatively could be used for operation in servo mode. If used in servo mode a phasing test is required at every power-up.

Type	Encoder	Description	Pr x.15
Incremental	Ab	Quadrature incremental encoder. With or without marker pulse.	0
	Fd	Incremental encoder with frequency and direction outputs. With or without marker pulse.	1
	Fr	Incremental encoder with forward and reverse outputs. With or without marker pulse.	2
	SC	SinCos encoder with no serial communications No optional marker pulse.	6

Quadrature detection logic determines rotation from the phase relationship of the two channels.

These encoders are available with a marker pulse, which identifies each individual rotation of the disc, and is also used to reset the drive position parameter. The incremental encoder can be used when operating in Closed Loop Vector mode, with the optional marker pulse not being required for correct operation.

NOTE

With this type of feedback the Unidrive SP must carry out a phasing test to find the phase offset angle on power up for operation in servo mode.

SC

In this case the incremental positional information and rotation is determined from the phase relationship of the analogue sine/cosine feedback signals. The incremental SinCos encoder can be used when operating in the Closed Loop Vector mode.

NOTE Refer to for section 3.4.6 *Comms only, (absolute encoders) SSI and EndAt* on page 15 for further information on the SinCos encoder feedback signals.

Limitations			
Type	Encoder	Max Input Frequency	Max no. of Lines (LPR)
Incremental	Ab	600kHz*	50,000
	Fd		
	Fr		
	SC	115kHz* (full resolution) 250kHz (reduced resolution)	

* Max input frequency = LPR x max rpm / 60

NOTE The maximum speed in rpm which an encoder connected to the SM-Encoder Plus can reach can be calculated from:

$$\text{Max rpm} = (60 \times \text{Max input frequency}) / \text{Encoder LPR}$$

e.g. For a 4096 line encoder the maximum rpm would be:

$$(60 \times 600 \times 10^3) / 4096 = 8789\text{rpm}$$

NOTE The absolute maximum input frequency for any SC, SinCos encoder used with the SM-Universal Encoder Plus is 250 kHz.

NOTE With this type of feedback the Unidrive SP must carry out a phasing test to find the phase offset angle on power up for operation in servo mode.

3.4.2 SinCos encoder feedback signals

For the SinCos encoder to be compatible with the SM-Universal Encoder Plus, the output signals from the encoder must be a 1V peak to peak differential voltage (across sinref to sin and cosref to cos).

Figure 3-4 Stegmann SinCos encoder feedback signals

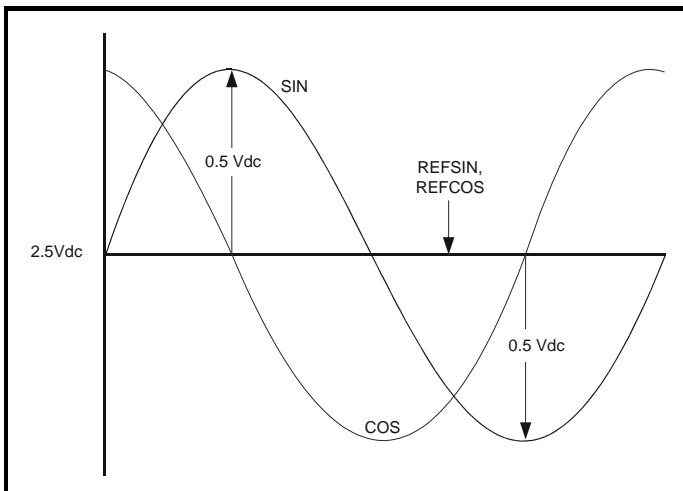

Stegmann

Stegmann encoders typically have a 2.5Vdc offset. The sinref and cosref are a flat DC level at 2.5Vdc and the cos and sin signals have a 1V peak to peak waveform biased at 2.5Vdc.

The result is a 1V peak to peak differential voltage as show in Figure 3-4.

Heidenhain

The Heidenhain Sin and Cos signals with respect to zero volts are offset at 2.5Vdc as shown in Figure 3-5.

The feedback signals which are seen by the SM-Universal Encoder Plus are the differential signals Sin - Sin\ and Cos - Cos\ as in Figure 3-5, these being 90° phase shifted and at 1Vdc peak to peak.

Figure 3-5 Heidenhain SinCos encoder feedback signals

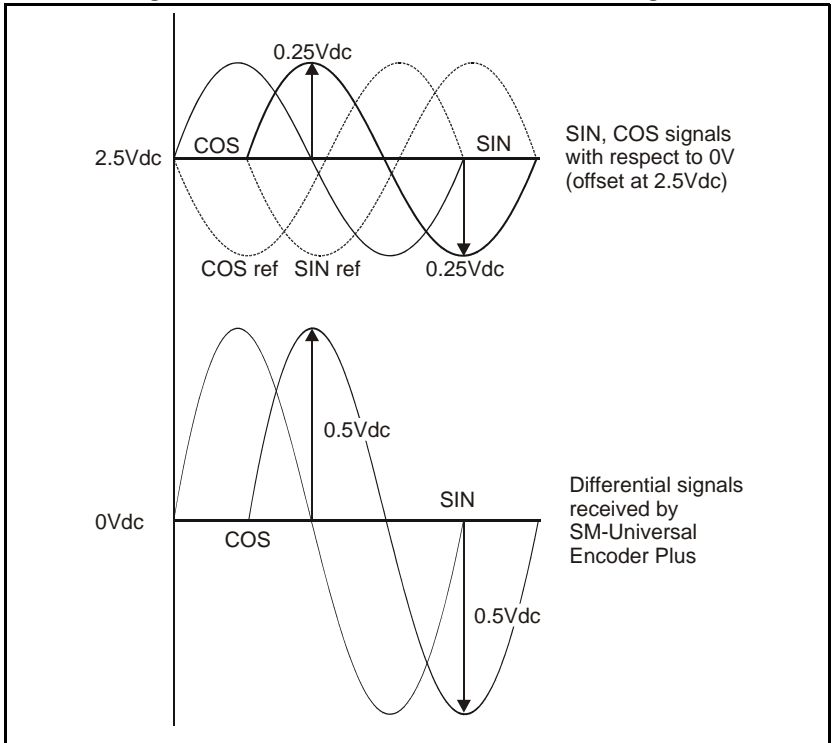

Encoders are available which have a 1V peak to peak voltage on sinref, sin, cos and cosref. This results in a 2V peak to peak voltage seen at the Solutions Module terminals. The drive will still function with this type of encoder, however reduced performance in the form of speed and torque ripple at four times the line rate will result.

(line rate = no. of lines per revolution x revolutions per second.)

NOTE

It is recommended that encoders of this type are not used with Unidrive SP, and that the encoder feedback signals should meet the above parameters (1V peak to peak).

3.4.3 SinCos Signal Values

When operating with a SinCos encoder, which has no comms or commutation signal inputs (Pr x.15 = 6), the internal differential SinCos signal values are written to both Pr x.42 (Sin) and Pr x.43 (Cos) as an unsigned numbers.
For further details refer to both Pr x.42 and Pr x.43

3.4.4 Incremental plus commutation, (absolute encoders) Ab.SErvo, Fd.SErvo, Fr.SErvo and SC.SErvo.

Type	Encoder	Description	Pr x.15
Incremental plus commutation (absolute encoders)	Ab.SErvo	Quadrature incremental encoder with commutation outputs. With or without marker pulse.	3
	Fd.SErvo	Incremental encoder with frequency, direction and commutation outputs. With or without marker pulse.	4
	Fr.SErvo	Incremental encoder with forward, reverse and commutation outputs With or without marker pulse.	5
	SC.SErvo	Absolute SinCos encoder plus commutation signals without marker pulse.	12

The incremental encoder with commutation works in the same way as the incremental encoder except that multiple channels are used to give a discrete code for every position increment.

When operating the drive in closed loop servo absolute position of the machine shaft is required as soon as the drive is enabled. Because the marker signal is not effective until the shaft passes a particular position, this cannot be used to determine the absolute position. Therefore an encoder with additional commutation is required.

NOTE *The U, V and W commutation signals should have a period that is one electrical revolution as shown in Figure 3-6.*

Therefore with a 6 pole machine the U, V and W commutation signals will repeat three times per mechanical revolution, or with an 8 pole machine four times per mechanical revolution etc.

The U, V and W commutation signals are used when the drive is enabled to locate the position of the machine shaft within 60° electrical so that the current vector can be applied within 30° electrical either side of the correct position for maximum torque production. At certain positions of the shaft, the torque capability of the drive during this period is reduced to 0.866 of the nominal level during initialisation.

Once the shaft has moved through a maximum of 60° electrical, one of the U, V or W signals will change state. The location of the waveform edge is used to locate the machine position exactly. This information is then stored by the option module and used until power-down to place the current vector in the correct position for maximum torque. To ensure that this process is carried out correctly the control algorithm waits for two changes of the state of the U,V and W waveforms, at this point there will be no additional torque ripple and maximum torque is available for all shaft positions.

Using this type of encoder does not result in any jump in position when the drive is first enabled after power-up, but only the small reduction in specification described above for the first 60 to 120° electrical of movement.

NOTE In Ab.SERVO, Fd.SERVO or Fr.SERVO mode only, the value in Pr x. 42 provides information on the commutation signal inputs (UVW). Pr x.42 permits the user to determine the current segment and status of the commutation signal inputs. For further details refer to Pr x.42

Figure 3-6 Example of encoder feedback signals

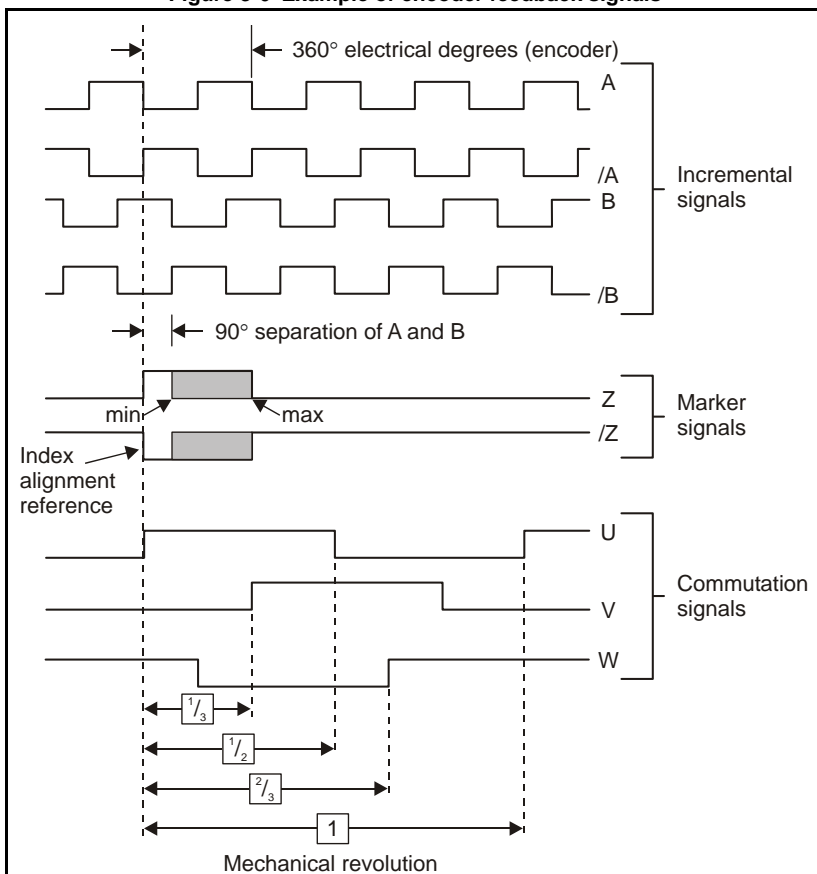

Limitations			
Type	Encoder	Max Input Frequency	Max no. of Lines (LPR)
Incremental plus commutation	Ab.SERVO	600kHz*	50,000
	Fd.SERVO		
	Fr.SERVO		
	SC.SERVO	115kHz* (full resolution) 250kHz (reduced resolution)	

* Max input frequency = LPR x max rpm / 60

NOTE The maximum speed in rpm which an encoder connected to the SM-Universal Encoder Plus can reach can be calculated from:

$$\text{Max rpm} = (60 \times \text{Max input frequency}) / \text{Encoder LPR}$$

e.g. For a 4096 line encoder the maximum rpm would be:

$$(60 \times 600 \times 10^3) / 4096 = 8789\text{rpm}$$

3.4.5 Incremental plus comms (absolute encoders) SC.HiPEr, SC.EndAt and SC.SSI

Type	Encoder	Description	Pr x.15
Incremental plus comms (absolute encoders)	SC.HiPEr	Absolute SinCos encoder using Stegmann RS485 comms protocol (HiperFace). The option module checks the position from the sine and cosine waveforms against the internal encoder position using serial communications. If an error occurs the drive trips.	7
	SC.EndAt	Absolute SinCos encoder using EndAt comms protocol The option module checks the position from the sine and cosine waveforms against the internal encoder position using serial communications. If an error occurs the drive trips.	9
	SC.SSI	Absolute SinCos encoder using SSI comms protocol The option module checks the position from the sine and cosine waveforms against the internal encoder position using serial communications.	11

NOTE It should be noted that the SC.HiPEr, SC.EndAt and SC.SSI encoders must be initialised before their position data can be used. The encoder is automatically initialised at power-up, after all trips are reset, or when the initialisation parameter (Pr 3.47) is set to 1. If the encoder is not initialised or the initialisation is invalid, the Solutions Module initiates a trip 7, and the drive will trip on SLX.Er.

NOTE A flux alignment test is required during set up to determine the phase offset angle for operation in servo mode.

The SC.HiPEr and SC.EndAt encoders can be considered as a mixture of an incremental encoder (analogue SinCos feedback signals) and an absolute encoder (serial link used for absolute position). The only difference between the encoders being the serial link protocol.

The RS 485 serial link allows the drive at power up to interrogate the SinCos encoder in comms channel order to determine the initial absolute position of the encoder shaft. When the interrogation is complete and the initial absolute position is known the position is incremented from the absolute value using the analogue sine/cosine interface. The comms channels can then be used for either error checking, Pr x.17 or data transfer, Pr x.42 to Pr x.43. The incremental SinCos encoder can be used when operating in either Closed Loop Vector or Closed Loop Servo modes.

Limitations				
Type	Encoder	Max Input Frequency *	Max no. of Lines (LPR)	Max Baud Rate (bits/s)
Incremental plus commutation	SC.HiPEr	115kHz (full resolution) 250kHz (reduced resolution)	50,000	9600k
	SC.EndAt			2M
	SC.SSI			

* Max input frequency = LPR x max rpm / 60

NOTE The maximum speed in rpm which an encoder connected to the SM-Encoder Plus can reach can be calculated from:

$$\text{Max rpm} = (60 \times \text{Max input frequency}) / \text{Encoder LPR}$$

e.g. For a 4096 line encoder the maximum rpm would be:

$$(60 \times 600 \times 10^3) / 4096 = 8789\text{rpm}$$

NOTE The absolute maximum input frequency for any SC, SinCos encoder used with the SM-Universal Encoder Plus is 250 kHz.

3.4.6 Comms only, (absolute encoders) SSI and EndAt

Type	Encoder	Description	Pr x.15
Comms (absolute)	EndAt	Absolute EndAt only encoder Additional communications with the encoder is not possible.	8
	SSI	Absolute SSI only encoder. Additional communications with the encoder is not possible.	10

NOTE It should be noted that EndAt and SSI encoders must be initialised before their position data can be used. The encoder is automatically initialised at power-up, after trips 1 - 8 are reset, or when the initialisation parameter (Pr 3.47) is set to 1. If the encoder is not initialised or the initialisation is invalid the Solutions Module initiates a trip 7, and the drive will trip on SLX.Err.

SSI, EndAt

Encoders with either an EndAt (transfer standard from Heidenhain) or SSI (Synchronous Serial) interface can transmit data synchronised with a CLOCK signal provided from the drive. This makes it possible to transmit position values quickly and reliably with only four signal lines.

The main difference between the SSI and the EndAt being that the standard SSI encoder is Uni-directional whereas the EndAt is Bi-directional. The data transfer for both the SSI and the EndAt takes the form of EIA Standard RS 485.

The SSI (Synchronous Serial interface) and EndAt (Encoder Data) encoders have a serial link between the encoder and drive which passes all positional information.

The encoder operates in the following manner:

1. A clock signal at a user defined frequency is sent out to the encoder.
2. Once a downward latching signal is detected by the encoder.
3. Followed by the data request.
4. The encoder then returns data to the drive at the clock frequency.

Limitations			
Type	Encoder	Max Baud Rate (bits/sec)	Max Speed rpm
Comms Only	EndAt	2Mbits/sec	40,000rpm
	SSI	2Mbits/sec	

NOTE The SSI input at default is configured to operate in Gray code through Pr **x.18**, this can be configured to operate in binary format by setting Pr **x.18** = 1. The simulated SSI encoder output will operate with both binary format and Gray code, the mode being configured through Pr **x.28**.

NOTE A flux alignment test is required during set up to determine the phase offset angle for operation in servo mode.

3.4.7 Linear Encoders

Type	Encoder	Description	Pr x.15
Linear encoder	Ab	Linear quadrature encoder	0
	SC	Linear SinCos encoder	6
	Ab.SErvo	Digital hall effect + Linear quadrature incremental encoder	3
	SC.SErvo	Digital hall effect + Linear SinCos incremental encoder	12
	SC.HiPEr	Linear absolute SinCos encoder	7
	SC.EndAt		9
	SC.SSI		11
	EndAt	Linear absolute encoder	8
	SSI		10

Linear Quadrature / SinCos Encoder

These types of encoder are purely incremental and have no information for commutation. With this type of feedback the Unidrive SP must carry out a phasing test to find the phase offset angle on every power up for operation in servo mode.

Digital Hall Effect + Linear Quadrature / SinCos Incremental encoder

These types of encoder have digital hall effect signals U, V, W plus complements that supply the necessary signals for deriving the position at power-up. The quadrature signals, incremental or SinCos are used for speed feedback. A flux alignment test is required during set-up to determine the phase offset angle for operation in servo mode.

Linear Absolute SinCos encoder

These types of encoder derive the absolute position at power-up via the comms protocol, HiPerface, EndAt or SSI with the incremental signals, SinCos, being used for incremental position and speed feedback.

A flux alignment test is required during set-up to determine the phase offset angle for operation in servo mode.

Linear Absolute encoder

These types of feedback are comms only encoders, which derive the position at power-up via either the EndAt or SSI comms protocols. The position feedback is also passed via comms during operation. The comms only encoders operate with the drive being the master and passing the required clock signal. A flux alignment test is required during set-up to determine the phase offset angle for operation in servo mode.

NOTE Refer to section 3.4.2 *SinCos encoder feedback signals* on page 10 for further information on the SinCos encoder feedback signals.

Limitations				
Type	Encoder	Max input frequency	Max no. of lines	Max baud rate
Linear encoder	Ab	600kHz	50,000	
	Ab.SERvo			
	SC			
	SC.SERvo	115kHz (full resolution) 250kHz (reduced resolution)		
	SC.HiPEr			9600k
	SC.EndAt			
	SC.SSI			2Mbits/sec
	EndAt			
	SSI			

NOTE In some applications using Closed Loop Vector control, the maximum speed of the system is above the speed at which the encoder feedback frequency is too high to be used by the drive. For these types of applications Pr **3.24** Closed Loop Vector Mode should be set to 2 (Closed Loop Vector Mode with no maximum speed limit) for low speed operation and 3 (Closed Loop Vector Mode without position feedback and with no maximum speed limit) for high-speed operation. It should be noted that the drive no longer checks that the maximum encoder frequency cannot be exceeded, and so the user must ensure that Pr **3.24** is set to 3 before the encoder frequency limit is reached.

4 Encoder feedback selection

4.1 Encoder selection

The SM-Universal Encoder Plus option module supports a total of 12 encoder types. These range from Quadrature relative encoders to Quadrature plus Commutation, SinCos plus Comms and Comms only absolute encoders.

When selecting an encoder there are essentially two groups these being absolute and relative. Absolute encoders providing the absolute position at power-up to the drive and only requiring a phasing test during the initial set-up when used for closed loop servo operation. Relative encoders requiring a phasing test at every power up when used for closed loop servo operation.

Either absolute or relative encoders can be used for closed loop vector operation.

4.1.1 Absolute encoders

The absolute encoders which are compatible with Unidrive SP are as follows:

- Ab.SERvo, Fd.SERvo, Fr.SERvo, SC.SERvo
- SC.HiPEr, SC.EndAt, SC.SSI
- EndAt, SSI

4.1.2 Non absolute encoders

At power up the encoder counters will start to increment from the incremental position as the encoder rotates, the position is reset to zero on detection of the first marker.

Compatible relative encoders being:

- Ab, Fd, Fr
- SC

4.1.3 Standard feedback

Basic encoder (Ab, Fd, Fr)

- 6 wire (+ 2 for marker if required)
- Up to 50,000ppr
- Ab - quadrature signals (best noise immunity)
- Fd - frequency and direction
- Fr - forward and reverse
- Marker input (only connect if needed, low noise immunity)
- Freeze based directly on the encoder counter
- Termination control
- Wirebreak detection

NOTE A quadrature encoder will provide sufficient performance for most applications once tuned.

Servo encoders (Ab.SERvo, Fd.SERvo, Fr.SERvo, SC.SERvo)

- 12 wire (+ 2 for marker if required not SC.SERvo)
- Commutation signals used for motor control until two valid changes
- Ab, Fd, Fr and SC signals used for motor control after initial movement, and continuously for speed feedback.
- PPR non power of 2 from S/W version 1.06.01
- Marker input (not SC.SERvo)
- Freeze based directly on the encoder counter
- Termination control (not for commutation signals)
- Wirebreak detection
- Phase error detection based on commutation signals

Non-absolute SINCOS encoder (SC)

- 6 wire
- Nominally the feedback resolution is sine waves per revolution plus 9 additional bits of interpolation information
- High resolution speed feedback, generally for induction motors but also servo motors with use of minimal movement phasing test
- No marker input
- Freeze is based on the time of the freeze event and interpolation between samples
- Wirebreak detection
- Initialisation required to align the analogue signals with the encoder counter

4.1.4 High resolution feedback

Stegmann Hiperface SINCOS encoders (SC.HiPEr)

- 8 wire
- 8 - 12V supply
- Absolute position determined via asynchronous comms
- Nominally the feedback resolution is sine waves per revolution plus 9 additional bits of interpolation information
- No marker input
- Freeze is based on the time of the freeze event and interpolation between samples
- Wirebreak detection
- Auto-configuration is possible
- Encoder phase error detection using comms
- Comms includes message XOR checksum
- Initialisation required to obtain the absolute position via comms and to align the analogue signals with the encoder counter

NOTE

An SC.HiPEr encoder will provide high performance and is recommended for precision applications.

Heidenhain EndAt SINCOS encoders (SC.EndAt)

- 10 wire
- 5V supply
- Absolute position determined via synchronous comms
- Nominally the feedback resolution is sine waves per revolution plus 9 additional bits of interpolation information
- No marker input
- Freeze is based on the time of the freeze event and interpolation between samples
- Wirebreak detection
- Encoder phase error detection using comms
- Comms includes CRC check
- Auto-configuration is possible
- Initialisation required to obtain the absolute position via comms and to align the analogue signals with the encoder counter
- Compatible with EndAt 2.1

NOTE

An SC.EndAt encoder will provide high performance and is recommended for precision applications.

SSI SINCOS encoders (SC.SSI)

- 10 wire
- Absolute position determined via synchronous comms
- Nominally the feedback resolution is sine waves per revolution plus 9 additional bits of interpolation information
- No marker input
- Freeze is based on the time of the freeze event and interpolation between samples
- Wirebreak detection
- Auto-configuration is not possible
- Encoder phase error detection using comms
- The comms protocol does not include any error checking
- Initialisation required to take the absolute position via comms and to align the analogue signals with the encoder counter
- Gray code or binary format encoders
- Power supply fail bit monitoring

SSI only encoder (SSI)

- 8 wire
- Position obtained via synchronous comms
- Not auto configurable, no error checking, too slow for use as motor feedback
- Feedback resolution defined by comms resolution
- No marker input
- Freeze is based on the time of the freeze event and interpolation between samples
- Wirebreak detection by comms error
- Gray code or binary format encoders
- Power supply fail bit monitoring

NOTE

SSI only encoders are not recommended for use as motor feedback, but can be used for either positioning or reference.

EndAt only encoders (EndAt)

- 8 wire
- 5V supply
- Position obtained via synchronous comms
- Feedback resolution defined by comms resolution
- No marker input
- Freeze is based on the time of the freeze event and interpolation between samples
- Wirebreak detection by comms error
- Comms includes CRC check
- Auto-configuration is possible
- Compatible with EndAt 2.1 (present version)
- Will allow access to interpolated position, but not extended functions with EndAt 2.2

NOTE

An EndAt encoder will provide high performance and is recommended for precision applications.

4.2 Considerations

When selecting an encoder there are a number of considerations, as follows, with these being application, drive operation, and encoder specification dependant.

4.2.1 Application dependant

1. Operating mode
2. Is the application a positioning application where high resolution is required

3. Is absolute position required at every power up, for example for operation in servo mode where a phasing test is not possible at every power-up
4. What resolution is required (e.g. AB 1024 encoder = 10bit resolution, SC.HiPEr 1024 = 19 bit resolution)
5. What environment is the encoder to be installed in
6. What cable lengths are to be used (encoders with comms do have restricted cable lengths due to comms baud rate)
7. Encoder supply voltage should be selected dependant upon the cable lengths due to voltage drop
8. Are motor objects to be saved to the encoder

4.2.2 Drive operation dependant

1. When operating in closed loop servo mode the drive requires the absolute position at power-up, be this from an absolute encoder or through a phasing test at every power-up
2. When operating in closed loop vector either an absolute or non-absolute encoder can be used
3. Encoder power supply and loading when operating with long cable lengths

4.2.3 Encoder specification dependant

1. Encoder voltage levels, are these compatible with the drive
2. Incremental encoder signals are these compatible (SC, Ab, Fr, Fd)
3. Incremental signals do not exceed maximum input frequency for option module
4. Comms encoder protocol is compatible (HiPEr, EndAt, SSI)
5. Comms encoder baud rate is compatible with drive
6. Application cable lengths do not exceed incremental signals cable length
7. Application cable lengths do not exceed the recommended cable length for comms operation, this being baud rate specific.
8. Encoder loading does not exceed encoder power supply from module (external power supply should be used if this is the case).

4.2.4 Encoder data

The following table compares compatible encoders for Unidrive SP

Type		Positional Resolution	Absolute Mode	Turns	Cost	Wires	Update rate	IP Rating	Supply voltage
AB, Fd, Fr	Incremental + Marker	15bit	None		Lowest	6	Fast	50 64	5 – 30
AB.SERvo Fd.SERvo Fr.SERvo	Incremental + Commutation + Marker	15bit	Cntrl.only		Low	12/14	Fast	50 64	5 – 30
SinCos	Incremental	15bit + 9bit = 24bit	None	Single or Multi	Medium	6	Fast	40	7 – 12
SC.SERvo	Incremental + Commutation	15 bits	Full	Single or Multi	Medium	12	Fast	40	7 – 12
SC.HiPEr	Incremental + Comms	15bit + 9bit = 24bit	Full	Single or Multi	High	8	Fast	40	7 – 12
SC.EndAt	Incremental + Comms	15bit + 9bit = 24bit	Full	Single or Multi	High	10	Fast	67	5
SC.SSI	Incremental + Comms	15bit + 9bit = 24bit	Full	Single or Multi	High	10	Fast	64 65 66	10 – 32
EndAt	Comms	15	Full	Single or Multi	High	6	Fast	67	5
SSI	Comms	15	Full	Single or Multi	Medium	6	Slow	64 65 66	10 – 32

4.3 Drive resolution / Feedback accuracy

The following values calculated are not a direct representation of performance at the motor shaft, with the motors inductance and load inertia smoothing out the shaft value to a much lower level. The value calculated is the instantaneous change in the **internal speed feedback** value seen by the drive between sample periods, and when the number of counts per revolution changes by 1 count.

This change is due to at any given speed it is unlikely that the number of counts per sample period will always be a whole number i.e. 1 in 10 sample periods may have an extra pulse to ensure the average speed is as demanded.

4.3.1 Available resolution

NOTE

The following Quadrature and SinCos type incremental encoders are available with various lines per revolution with the Unidrive SP being compatible with encoders ranging from 1 PPR (4 CPR) to 50,000 PPR (200,000CPR).

The comms only encoders which include both EndAt and SSI are also available with various comms resolutions with Unidrive SP being compatible up to 32bits.

Ab Quadrature Incremental Encoder

- A 4096 LPR encoder has 4096 pulses per channel, and 16,384 edges. Available resolution = 16,384 counts / turn.

SC Incremental Encoder

- An SCS50 SinCos encoder has 1024 sine waves per revolution with the drive interpolating each sine wave to 9bits worth of resolution giving a total resolution of $2 \times 1024 \times 512 = 1,048,576$ counts per revolution

EndAt Comms Only Encoder

- An EndAt comms only encoder has 13 bits giving a total resolution of = 8192 counts per revolution

Comparing a 4096 PPR incremental encoder to a SCS50 SinCos encoder the SCS50 SinCos encoder will have a factor of 128 less ripple than the 4096 PPR encoder.

Therefore the encoder selected can influence the digital torque ripple significantly and should be considered on high resolution / accuracy applications. The following table shows both the digital torque ripple and available resolution for various encoder types.

Feedback Device		Digital Torque Ripple	Available Resolution
Quadrature Incremental	1024	59rpm	4096
	4096	14rpm	16384
Comms	EndAt	29.43rpm	13bit
	EndAt	1.83rpm	17bit
SinCos Incremental	512	0.23rpm	2048 * 512
	1024	0.11rpm	4096 * 512

NOTE

The above figures are independent of the operating speed. If the figures are recalculated for a 750 rpm then the number of counts is halved but the speed change for 1 count is the same.

4.3.2 Internal digital torque ripple calculation

Following is an example of the internal digital torque ripple calculation

AB Quadrature Encoder

1024 line encoder running at 1500rpm and Unidrive SP speed loop sample time = 250us

- $1500\text{rpm} / 60\text{s} = 25 \text{ rev / s}$
- $25 \text{ rev / s} \times 1024\text{ppr} = 25600 \text{ pulses / s}$
- $25600 \text{ pulses / s} \times 4\text{edges} = 102400 \text{ edges / s}$
- $102400 \text{ edges / s} \times 250 \times 10^{-6} = 25.6 \text{ edges per sample period}$

Therefore due to the digitisation of the encoder feedback the average number of edges seen will be 25.6, but this must be due to the relevant number of 25 and 26 edges over an infinite length of time. As such:

25 edges / $250 \times 10^{-6} = 100,000 \text{ edges / sec.}$

$100,000 / 4 = 25,000 \text{ edges}$

$25,000 / 1024 = 24.4 \text{ rev / s}$

$24.4 \times 60 = 1464.8 \text{ rpm}$

26 edges / $250 \times 10^{-6} = 104,000 \text{ edges/ sec.}$

$104,000 / 4 = 26,000 \text{ edges}$

$26,000 / 1024 = 25.4 \text{ rev / s}$

$25.4 \times 60 = 1523.4 \text{ rpm}$

$1523 - 1464 = 59\text{rpm}$

The difference of 1 pulse gives an instantaneous speed change of 59 rpm.

5 Installing the SM-Universal Encoder Plus

5.1 Solutions Module slots



Before installing the SM-Universal Encoder Plus, refer to Chapter 2 *Safety Information* on page 6.

There are three slots available, which the Solutions Module can be plugged into as shown in Figure 5-1. The Solutions Module can be plugged into either one of these, but it is recommended that slot 3 be used for the first Solutions Module then slot 2 and slot 1. This ensures maximum mechanical support for the Solutions Module once fitted.

Figure 5-1 Location of slots 1, 2 and 3 on the Unidrive SP

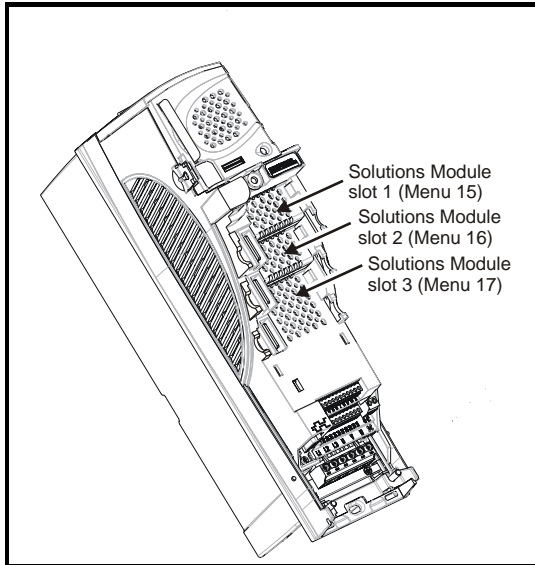

5.2 Installation

1. Before installing the SM-Universal Encoder Plus in the Unidrive SP, ensure the AC supply has been disconnected from the drive for at least 10 minutes.
2. Ensure that both the +24V, and +48V backup power supplies are disconnected from the drive for at least 10 minutes.
3. Check that the exterior of the SM-Universal Encoder Plus is not damaged, and that the multi-way connector is free from dirt and debris.
4. Do not install a damaged or dirty SM-Universal Encoder Plus in the drive.
5. Remove the terminal cover from the drive. (For removal / re-fitting instructions, see *Unidrive SP Solutions Module Installation Sheet* provided with the Solutions Module.)
6. Position the drive connector of the SM-Universal Encoder Plus over the connector of the appropriate slot in the drive and push downwards until it locks into place.

Figure 5-2 Fitting the SM-Universal Encoder Plus

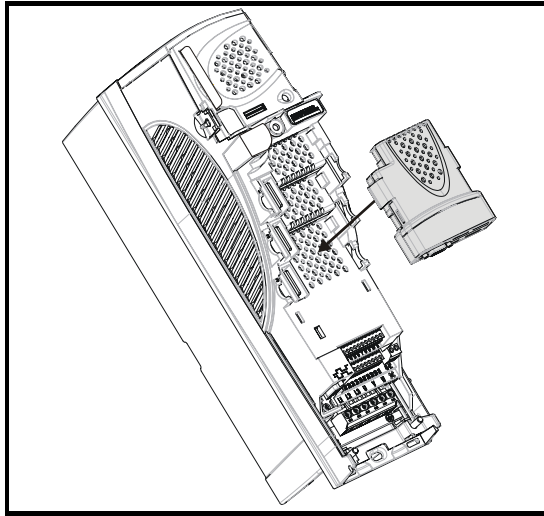

7. Re-fit the terminal cover to the drive. (For removal / re-fitting instructions, see *Unidrive SP Solutions Module Installation Sheet* provided with the Solutions Module.)
8. Connect the AC supply to the drive.
9. Set Pr **0.49** to L2 to unlock read only security.
10. Check that Menu 15 (slot 1), 16 (slot 2), or 17 (slot 3) parameters are now available.
11. Check that Pr **15.01**, Pr **16.01** or Pr **17.01** show the correct code for the SM-Universal Encoder Plus (code = 102).
12. If the checks in steps 10 and 11 fail, either the SM-Universal Encoder Plus is not fully inserted, or the Solutions Module is fault.
13. If a trip code is now present refer to Chapter 10 *Diagnostics* on page 98.

NOTE

Check the SM-Universal Encoder Plus is the correct issue and has the correct software.

- Issue 3 - **V.03.xx.xx**
- Issue 4 - **V.04.xx.xx**

Encoder connections

In order to ensure correct operation there are a number of checks which should be carried out:

- Ensure the encoder is securely mounted to the motor as spurious operation can result due to the encoder slipping whilst the motor is rotating.
- Ensure encoder connections to both the encoder and the Solutions Module terminals are secured, intermittent connections can result in spurious operation or the Solutions Module not detecting the feedback signals.
- Ensure screen and grounding recommendations as specified in Chapter 5.5 *Encoder shield connections* on page 28, Encoder, Shield connections of this User guide are followed to prevent noise being induced on the encoder feedback signals. Noise induced on encoder feedback cables cannot only result in spurious operation but in extreme cases can result in encoder failure and/or damage to the Solutions Modules encoder input.

- Encoder feedback and communications data is transmitted from an encoder as low voltage analogue or digital signals. Ensure that electrical noise from the drive or motor does not adversely affect the encoder feedback. Also refer to drive and motor instructions given in Chapter 4 *Electrical Installation* in the *Unidrive SP User Guide*, and that the encoder feedback wiring and shielding recommendations are followed in section 5.5 *Encoder shield connections* on page 28.

5.3 Terminal descriptions

Figure 5-3 Connector SK2 terminal descriptions

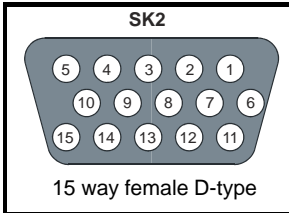

The standard connector SK2 provided on the SM-Universal Encoder Plus is a 15 way D-Type requiring a similar 15 way D-Type for connection of an encoder. A standard 15 way D-Type has solder connections, the following UT01 allows direct connection to the 15 way D-Type on the Solutions Module providing screw terminals for encoder connection.

Figure 5-4 15-way D-type converter

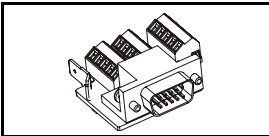

Each terminal is appropriately labelled on the printed circuit board.

Figure 5-5 Connector SK2 terminal descriptions

Term	Encoder													
	Ab	Fd	Fr	Ab. SErvo	Fd. SErvo	Fr. SErvo	SC	SC. HiPEr	EndAt	SC. EndAt	SSI	SC. SSI	SC. SErvo	
1	A	F	F	A	F	F	Cos			Cos		Cos		
2	A\	F\	F\	A\	F\	F\	Cosref			Cosref		Cosref		
3	B	D	R	B	D	R	Sin			Sin		Sin		
4	B\	D\	R\	B\	D\	R\	Sinref			Sinref		Sinref		
5	Z							Encoder input - Data (input/output)						
6	Z\							Encoder input - Data\ (input/output)						
7	Simulated encoder Aout, Fout, Data SSI (output)			U			Simulated encoder Aout, Fout, Data SSI (output)					U		
8	Simulated encoder Aout\, Fout\ Data\ SSI (output)			U\			Simulated encoder Aout\, Fout\, Data\ SSI (output)					U\		
9	Simulated encoder Bout, Dout, Clock SSI (input)			V			Simulated encoder Bout, Dout, Clock SSI (input)					V		
10	Simulated encoder Bout\, Dout\ Clock SSI (input)			V\			Simulated encoder Bout\, Dout\ Clock SSI (input)					V\		
11				W					Encoder input - Clock (output)			W		
12				W\					Encoder input - Clock\ (output)			W\		
13	+V													
14	0V common													
15	th													

NOTE The simulated encoder outputs present on terminals 7, 8,9,10 (A.A\, B.B\, F.F\, D.D\) can be through either software simulation or hardware, this being determined by Pr **x.28**

NOTE No simulated encoder output is available when operating with either of the following encoders configured at the modules input, Ab.SErvo, Fd.SErvo, Fr.SErvo, SC.SErvo due to the commutation signals using the same inputs/outputs as used by the simulated encoder output.

Figure 5-6 Connector PL1

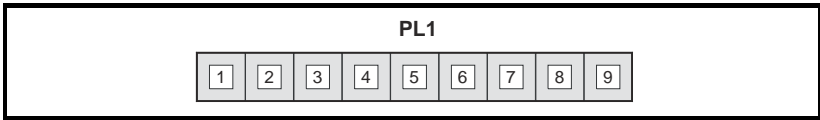

Table 5.1 Connector PL1 terminal descriptions

Terminal	Freeze inputs / Encoder outputs					
	Freeze RS485 input	Freeze +24V input	Ab output	Fd output	SSI output	Marker output
1		Freeze				
2	0V common					
3			A	F	Data	
4			A\<	F\<	Data\<	
5			B	D	Clock (input)	
6			B\<	D\<	Clock (input)	
7	0V common					
8	Freeze					Z
9	Freeze\<					Z\<

5.4 Power supply

The total user load of the drive and Solutions Modules if exceeded will result in a 24V internal power supply overload, trip 'PS.24V'.

The user load comprises of:

- the drive's digital outputs plus the SM-I/O Plus digital outputs or
- the drive's main encoder supply plus the SM-Universal Encoder Plus encoder supply

Example

If exceeding the user load:

- the drive's main encoder supply, SM-Universal Encoder Plus encoder supply, drive's digital output and SM-I/O Plus digital outputs

an external 24V >50W power supply will be required. The external 24V supply should be connected to the drives control terminals 1 and 2.

NOTE If the encoder will exceed the SM-Universal Encoder Plus and encoder supply (5V, 8V >300mA, 15V >200mA), the encoder must be supplied externally without a power supply connection to the module. Ensure the 0V connection is common between both the SM-Universal Encoder Plus and the encoder.

NOTE There should be no parallel connection of the external 24V supply and the encoder supply from the drive.

5.5 Encoder shield connections

Shielding considerations are important for PWM drive installations due to the high voltages and currents present in the output circuit with a very wide frequency spectrum, typically from 0 to 20 MHz. Encoder inputs are liable to be disturbed if careful attention is not given to managing the cable shields.

5.6 Grounding hardware

The Unidrive SP is supplied with a grounding clamp and a grounding bracket to facilitate EMC compliance. They provide a convenient method for direct grounding of cable shields without the use of "pig-tails". Cable shields can be bared and clamped to the grounding bracket using metal clips or clamps¹ (not supplied) or cable ties. Note that the shield must in all cases be continued through the clamp to the intended terminal on the drive, in accordance with the connection details for the specific signal.

A suitable clamp is the Phoenix DIN rail mounted SK14 cable clamp (for cables with a maximum outer diameter of 14mm).

See Figure 5-2 and Figure 5-3 for details on fitting the grounding clamp.

See Figure 5-4 for details on fitting the grounding bracket.

Figure 5-2 Fitting of grounding clamp (size 1 and 2)

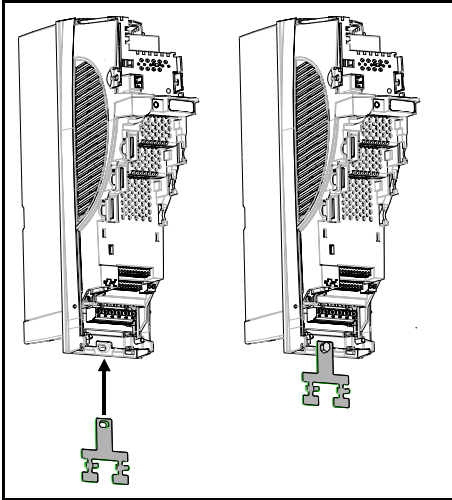

Figure 5-3 Fitting of grounding clamp (size 3)

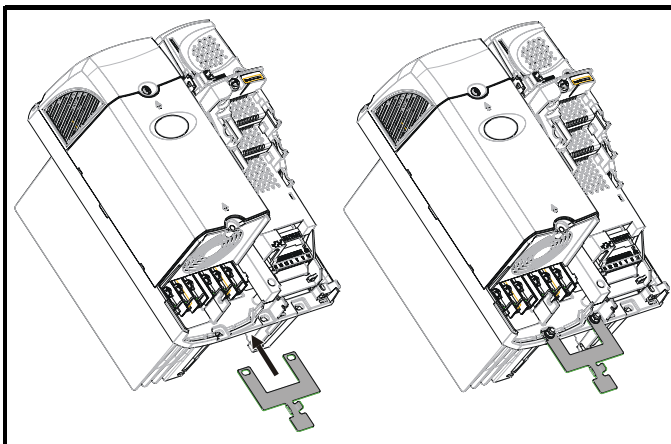
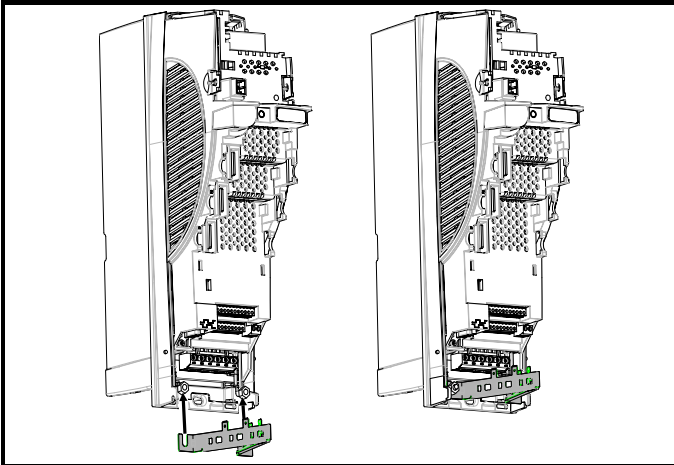

Figure 5-4 Fitting of grounding bracket (sizes 1 to 6)



Loosen the ground connection nuts and slide the grounding bracket in the direction shown. Once in place, re-tighten the ground connection nuts.



On Unidrive SP size 1 and 2, the grounding bracket is secured using the power ground terminal of the drive. Ensure that the supply ground connection is secure after fitting / removing the grounding bracket. Failure to do so will result in the drive not being grounded.

A faston tab is located on the grounding bracket for the purpose of connecting the drive 0V to ground should the user require to do so.

When a Unidrive SP size 4 or 5 is through-panel mounted, the grounding link bracket must be folded upwards. A screw can be used to secure the bracket or it can be located under the mounting bracket to ensure that a ground connection is made. This is required to provide a grounding point for the grounding bracket as shown in Figure 5-4.

Figure 5-5 Grounding link bracket in its surface mount position (as supplied with drive)

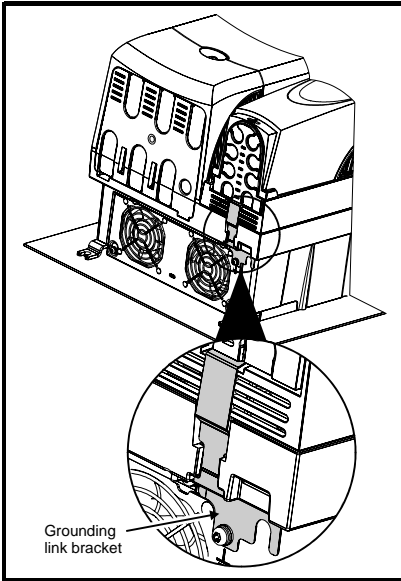
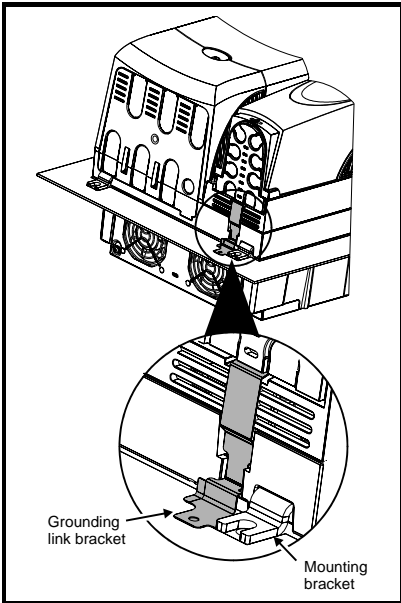
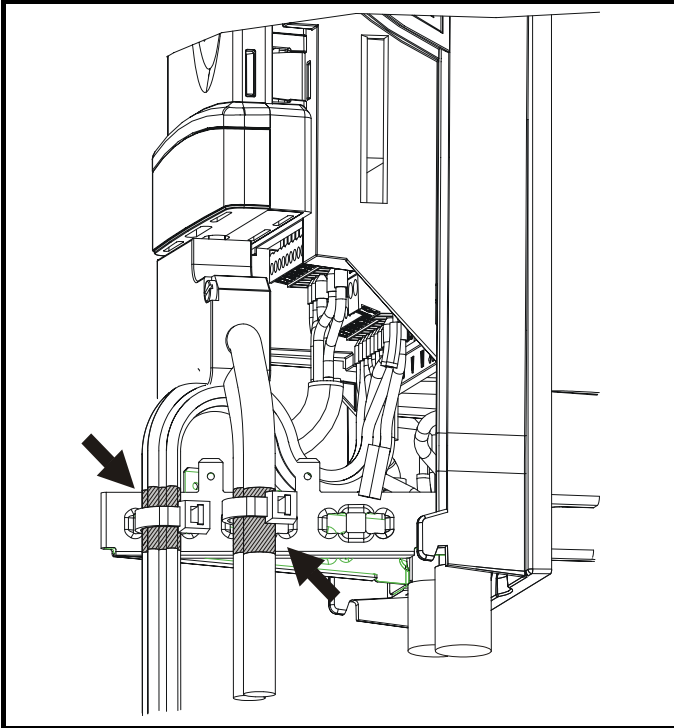

Figure 5-6 Grounding link bracket folded up into its through-panel mount position



If the control wiring is to leave the enclosure, it must be shielded and the shield(s) clamped to the drive using the grounding bracket as shown in Figure 5-7. Remove the outer insulating cover of the cable to ensure the shield(s) make contact with the bracket, but keep the shield(s) intact until as close as possible to the terminals. Alternatively, wiring may be passed through a ferrite ring, part no. 3225-1004.

Figure 5-7 Grounding of signal cable shields using the grounding bracket



Encoder mounting methods

There are three methods for mounting an encoder onto a motor:

1. Galvanic isolation between encoder and motor
2. Galvanic isolation between encoder circuit and encoder body
3. No Isolation

5.6.1 Encoder with galvanic isolation from motor

When galvanically isolated the encoder device is mounted to the motor with isolation fitted between the motor housing / shaft and encoder as shown in Figure 5-7.

Figure 5-7 Galvanic Isolation from Motor

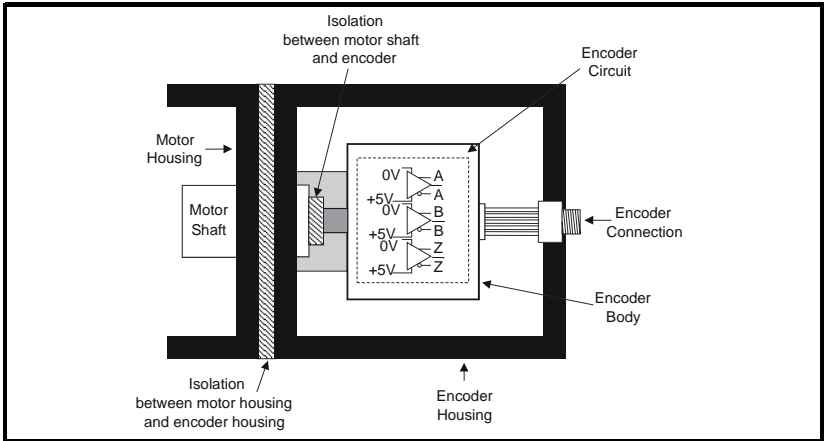

An example of this is the Unimotor where isolation from the motor is achieved by inserting a plastic mounting plate between the motor housing and encoder housing and a plastic insert fitted in the motor shaft for encoder mounting to the motor shaft. With this preferred method of mounting noise current is prevented from passing from the motor housing into the encoder housing, and hence into the encoder cable. The ground connection of the cable shield is optional, this may be required to comply with safety measures or to reduce radiated radio frequency emissions from either the drive or encoder.

5.6.2 Encoder circuit with galvanic isolation from encoder body

In this case the encoder device is mounted directly on the motor housing with contact being made between the motor housing/shaft and encoder. With this mounting method the encoder internal circuits are exposed to electrical noise from the motor housing through the stray capacitance, and they must be designed to withstand this situation. However this arrangement still prevents large noise currents from flowing from the motor body into the encoder cable. The ground connection of the cable shield is optional, this may be required to comply with safety measures or to reduce radiated radio frequency emissions from either the drive or encoder.

Figure 5-8 Encoder Galvanically Isolated from Encoder Body

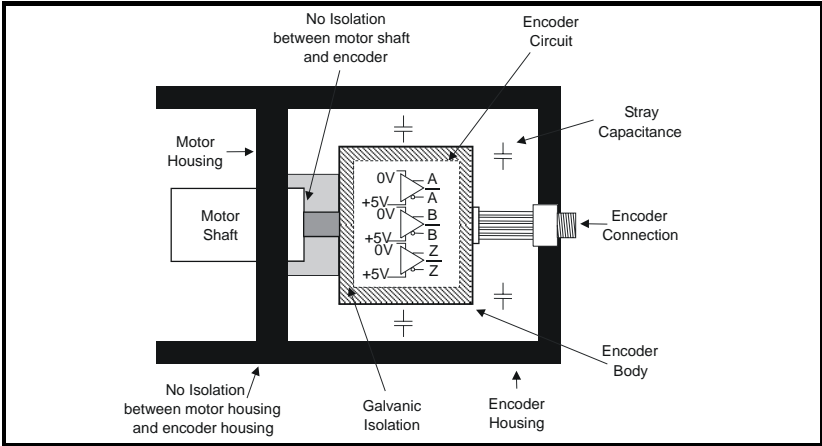

5.6.3 No isolation

As shown in Figure 5-9 the encoder 0V connection may be permanently connected to the housing. This has the advantage that the encoder body can form a shield for its internal circuits. However it permits noise current from the motor body to flow into the encoder cable shield. A good quality shielded cable correctly terminated protects the data against this noise current, but much more care is needed in ensuring correct cable management than for the isolated cases.

Figure 5-9 No Isolation

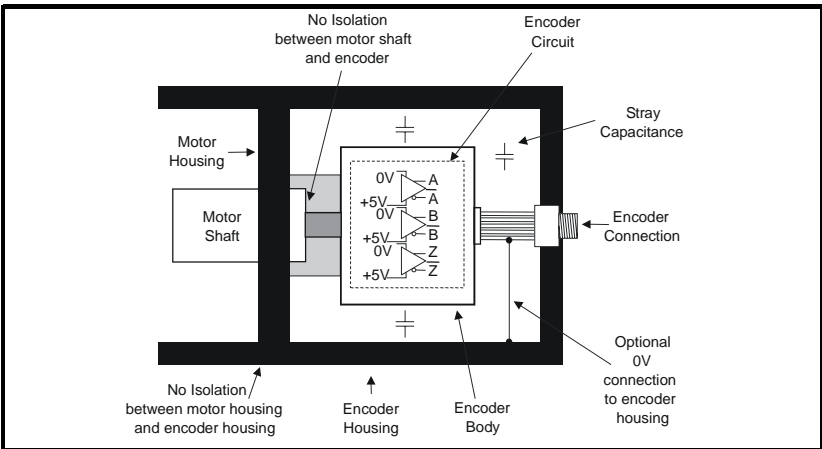

5.6.4 Cable requirements

All mounting methods:

- Shield connection at drive terminal to 0V
- Shield connection at encoder to 0V
- It is recommended that the shielded cable should be run in a continuous length to the terminal, to avoid the injection of noise at intermediate pigtails and to maximise the shielding benefit.
- The shield connections ("pigtails") to the drive and encoder should be kept as short as possible

Mounting with no isolation:

- Shield connected to ground at both ends. The connection must be made by direct fixing of the cable to the grounded metal parts, i.e. to the encoder body and the drive grounding bracket, as illustrated in Figure 5-7 on page 33. "Pigtails" must be avoided. The outer sheath of the cable should be stripped back enough to allow for the ground clamp to be fitted. The shield connection should not be broken. The ground clamps should be located as close as possible to the drive and encoder.
- It is essential that the shielded cable should be run in a continuous length to the terminal, to avoid the injection of noise at intermediate "pigtails" and to maximise the shielding benefit.



In this case under no circumstances must the cable shield connection be omitted at either end of the cable in this case, since the noise voltage may well be sufficient to destroy the line driver and receiver chips in the encoder and the drive.

Cable shield ground connection

For all mounting methods, grounding of the feedback cable shield has added benefits. It can protect the drive and encoder from induced fast electrical transients, and prevent radiated radio-frequency emission. However it is essential that it be carried out in the correct manner as explained above and shown in Figure 5-11 on page 36.



Connecting the cable shield to ground at both ends carries the risk that an electrical fault might cause excessive power current to flow in the cable shield and overheat the cable. There must be an adequately rated safety ground connection between the motor/encoder and the drive.

Recommended cable

The recommended cable for feedback signals is a twisted pair, shielded with an overall shield as shown in Figure 5-10

Figure 5-10 Feedback Cable, Twisted Pair

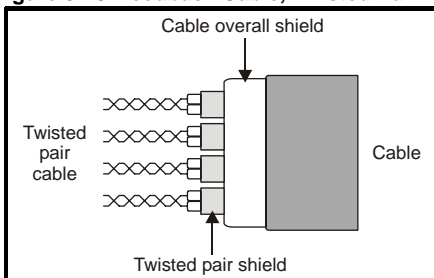

Using this type of cable also allows for the connection of the outer shield to ground and the inner shields to 0V alone at both drive and encoder end, when required.

NOTE Ensure that feedback cables are kept as far away as possible from power cables and avoid parallel routing.

Figure 5-11 Feedback cable connections

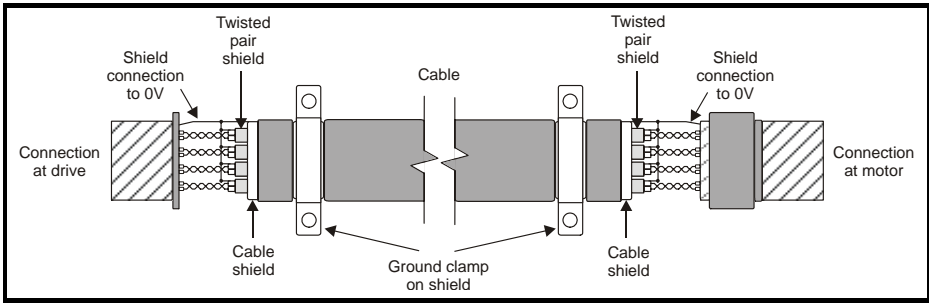

6 Getting Started

6.1 Installation



The control circuits are isolated from the power circuits in the drive by basic insulation only, as specified in IEC60664-1. The installer must ensure that the external control circuits are insulated from human contact by at least one layer of insulation rated for use at the AC supply voltage.

If the control circuits are to be connected to other circuits classified as Safety Extra Low Voltage (SELV) (e.g. to a personal computer) an additional isolating barrier must be included in order to maintain the SELV classification.

Encoder connections

In order to ensure correct operation there are a number of checks which should be carried out:

- Ensure the encoder is securely mounted to the motor as spurious operation can result due to the encoder slipping whilst the motor is rotating.
- Ensure encoder connections to both the encoder and the Solutions Module terminals are secured, intermittent connections can result in spurious operation or the Solutions Module not detecting the feedback signals.
- Ensure screen and grounding recommendations as specified in Chapter 5.5 *Encoder shield connections* on page 28, Encoder, Shield connections of this User guide are followed to prevent noise being induced on the encoder feedback signals. Noise induced on encoder feedback cables cannot only result in spurious operation but in extreme cases can result in encoder failure and/or damage to the Solutions Modules encoder input.

Encoder feedback and communications data is transmitted from an encoder as low voltage analogue or digital signals. Ensure that electrical noise from the drive or motor does not adversely affect the encoder feedback. Also refer to drive and motor instructions given in Chapter 4 *Electrical Installation* in the *Unidrive SP User Guide*, and that the encoder feedback wiring and shielding recommendations are followed in section 5.5 *Encoder shield connections* on page 28.

Encoder initialisation

Encoder initialisation will occur as follows: at drive power-up, when requested by the user via Pr 3.47 or when trips in this module (which are option module specific) are reset. Initialisation causes an encoder with comms to be re-initialised and auto-configuration to be performed if selected. After initialisation Ab.SERvo, Fd.SERvo, Fr.SERvo and SC.SERvo encoders will use the UVW commutations signals to give position feedback for the first 120° (electrical) of rotation when the motor is restarted.

A delay is provided during initialisation for some encoders to allow the encoder to be ready to provide position information after it has powered up. The delay is provided during initialisation because this occurs during drive power-up and after encoder power supply trips are reset. The delays are as follows:

Encoder type	Initialisation delay
Ab, Fd, Fr, Ab.SERvo, Fd.SERvo, Fr.SERvo, SC.SERvo	250ms
SC.HiPEr	150ms, then encoder reset, then 400ms
SC.EndAt, EndAt	1.25s
All other types	1.45s

NOTE Encoder initialisation will only occur when trips 1 through to 74 in Pr **x.50**, Solutions Module error status are reset.

Pr x.18 Auto-configuration enable\SSI binary format select

When a SC.HiPEr or SC.EndAt encoder is being used, the Solutions Module will interrogate the encoder on power-up. If Pr **x.18** is set and the encoder type is recognised based on the information provided by the encoder, the Solutions Module will set the encoder turns Pr **x.09**, the equivalent lines per revolution Pr **x.10** and the encoder comms resolution Pr **x.11** for the encoder. If the encoder is recognised these parameters will all become read only. If the encoder is not recognised, the Solutions Module will initiate a 7 trip to prompt the user to enter the information. The Solutions Module should be able to auto-configure with any EndAt encoder where the number of turns and lines per revolution are a power of 2, and the following Hiperface encoders: SCS 60/70, SCM 60/70, SRS 50/60, SRM 50/60, SHS 170, LINCORDER, SCS-KIT 101, SKS36, SKM36, SEK52, SEK53.

NOTE When operating with an SSI encoder, Pr **x.18** is used to set-up the data format: 0 = Gray code and 1 = binary format.

NOTE When using only the simulated encoder outputs from the SM-Universal Encoder Plus, the error detection Pr **x.17** should be disabled to avoid Enc2 trips.

6.1.1 Incremental encoders

The following parameter set-up should be followed when configuring an Incremental Encoder.

Incremental Encoders, Ab, Fd, Fr, SC									
Before power-up	Ensure: <ul style="list-style-type: none"> Feedback device is connected Drive secure disable is not given (terminal 31) 								
Power-up drive	Ensure: <ul style="list-style-type: none"> Drive displays "inh" If the drive trips refer to Chapter 10 <i>Diagnostics</i> on page 98 								
Slot identification	Identify: <ul style="list-style-type: none"> Identify slot and associated menu, 15, 16, or 17 								
Select Solutions Module	Enter: <ul style="list-style-type: none"> Speed feedback selector Pr 3.26 1: Slot 1, 2: Slot 2, 3: Slot 3 								
Set-up encoder power supply	Enter: <ul style="list-style-type: none"> Encoder power supply Pr x.13 0: 5v, 1: 8v, 2:15v 								
Set-up encoder type	Enter: <ul style="list-style-type: none"> Encoder Type Pr x.15 0 (Ab), 1 (Fd), 2 (Fr), 6(SC) 								
Set-up encoder lines per revolution	<ul style="list-style-type: none"> Equivalent lines per revolution Pr x.10 Set according to encoder, see below for restrictions Line per revolution divider Pr x.46 The equivalent lines per revolution Pr x.10 is divided by the value in Pr x.46. This can be used when an encoder is used where the number of lines or sine waves per pole is not an integer e.g. 128.123 lines per rev = 128.123 in Pr x.10 and 1000 in Pr x.46 giving $128.123/1000 = 128.123$. <table border="1" style="margin-left: 40px;"> <thead> <tr> <th>Encoder</th> <th>Pr x.10 Equivalent lines per revolution</th> </tr> </thead> <tbody> <tr> <td>Ab</td> <td>Number of lines per revolution</td> </tr> <tr> <td>Fd, Fr</td> <td>Number of lines per revolution / 2</td> </tr> <tr> <td>SC</td> <td>Number of sine waves per revolution</td> </tr> </tbody> </table>	Encoder	Pr x.10 Equivalent lines per revolution	Ab	Number of lines per revolution	Fd, Fr	Number of lines per revolution / 2	SC	Number of sine waves per revolution
Encoder	Pr x.10 Equivalent lines per revolution								
Ab	Number of lines per revolution								
Fd, Fr	Number of lines per revolution / 2								
SC	Number of sine waves per revolution								
Set-up encoder turns	<ul style="list-style-type: none"> Encoder turns Pr x.09 Defines the maximum number of the revolution counter (when operating with an incremental encoder) before it rolls over at zero e.g. if Pr x.09 = 5, then Pr x.04 counts up to 31 before rolling over at zero. 								
Error detection	Ensure: <ul style="list-style-type: none"> The required error detection is set-up in Pr x.17 								
Initialisation	Ensure: <ul style="list-style-type: none"> Position feedback is initialised Pr x.45 A re-initialise can be carried out enabling Pr 3.47 								

NOTE When operating in servo mode with either of the above Incremental encoders a flux alignment test (Pr **5.12**) is required at every power up in order to determine the phase offset angle. The minimal movement flux alignment test can be set-up through Pr **5.14** to carry out the required test automatically at every power up.

6.1.2 Incremental plus commutation, absolute encoders

The following parameter set-up should be followed when operating with an incremental plus commutation absolute encoder.

Incremental plus commutation, absolute encoders, Ab.SErvo, Fd.SErvo, Fr.SErvo, SC.SErvo											
Before power-up	Ensure: <ul style="list-style-type: none"> Feedback device is connected Drive secure disable is not given (terminal 31) 										
Power-up drive	Ensure: <ul style="list-style-type: none"> Drive displays "inh" If the drive trips refer to Chapter 10 <i>Diagnostics</i> on page 98 										
Slot identification	Identify: <ul style="list-style-type: none"> Identify slot and associated menu, 15, 16, or 17 										
Select Solutions Module	Enter: <ul style="list-style-type: none"> Speed feedback selector Pr 3.26 1: Slot 1, 2: Slot 2, 3: Slot 3 										
Set-up encoder power supply	Enter: <ul style="list-style-type: none"> Encoder power supply Pr x.13 0: 5v, 1: 8v, 2: 15v 										
Set-up encoder type	Enter: <ul style="list-style-type: none"> Encoder Type Pr x.15 3 (Ab.SErvo), 4 (Fd.SErvo), 5 (Fr.SErvo), 12 (SC.SErvo) 										
Set-up encoder lines per revolution	<ul style="list-style-type: none"> Equivalent lines per revolution Pr x.10 Set according to encoder, see below for restrictions <table border="1" style="margin-left: 20px;"> <thead> <tr> <th>Encoder</th> <th>Pr x.10 Equivalent lines per revolution</th> </tr> </thead> <tbody> <tr> <td>Ab.SErvo</td> <td>Number of lines per revolution</td> </tr> <tr> <td>Fd.SErvo</td> <td>Number of lines per revolution / 2</td> </tr> <tr> <td>Fr.SErvo</td> <td></td> </tr> <tr> <td>SC.SErvo</td> <td>Number of sine waves per revolution</td> </tr> </tbody> </table>	Encoder	Pr x.10 Equivalent lines per revolution	Ab.SErvo	Number of lines per revolution	Fd.SErvo	Number of lines per revolution / 2	Fr.SErvo		SC.SErvo	Number of sine waves per revolution
Encoder	Pr x.10 Equivalent lines per revolution										
Ab.SErvo	Number of lines per revolution										
Fd.SErvo	Number of lines per revolution / 2										
Fr.SErvo											
SC.SErvo	Number of sine waves per revolution										
Set-up encoder turns	<ul style="list-style-type: none"> Encoder turns Pr x.09 Defines the maximum number of the revolution counter (when operating with an incremental encoder) before it rolls over at zero e.g. Pr x.09 = 5, then Pr x.04 counts up to 31 before rolling over at zero.										
Error detection	Ensure: <ul style="list-style-type: none"> The required error detection is set-up in Pr x.17 										
Initialisation	Ensure: <ul style="list-style-type: none"> Position feedback is initialised Pr x.45 A re-initialise can be carried out enabling Pr 3.47 										

NOTE When using the above incremental plus commutation, absolute encoders Pr **x.46** lines per revolution divider should remain at 1 to ensure correct operation.

6.1.3 Incremental absolute encoders

The following parameter set up should be followed when configuring an incremental absolute encoder.

Incremental absolute encoders, SC.HiPEr, SC.EndAt, SC.SSI	
Before power-up	Ensure: <ul style="list-style-type: none"> Feedback device is connected Drive secure disable is not given (terminal 31)
Power-up drive	Ensure: <ul style="list-style-type: none"> Drive displays "inh" If the drive trips refer to Chapter 10 <i>Diagnostics</i> on page 98
Slot identification	Identify: <ul style="list-style-type: none"> Identify slot and associated menu, 15, 16, or 17
Select Solutions Module	Enter: <ul style="list-style-type: none"> Speed feedback selector Pr 3.26 1: Slot 1, 2: Slot 2, 3: Slot 3
Set-up encoder power supply	Enter: <ul style="list-style-type: none"> Encoder power supply Pr x.13 0: 5v, 1: 8v, 2:15v
Set-up encoder type	Enter: <ul style="list-style-type: none"> Encoder Type Pr x.15 7 (SC.HiPEr), 9 (SC.EndAt), 11 (SC.SSI)
Encoder comms	<ul style="list-style-type: none"> Encoder comms baud rate Pr x.14 (EndAt, SSI) Encoder comms resolution Pr x.11 <p>Where encoder comms is used for initial setting of the absolute position the comms resolution in bits must be set correctly. The comms resolution, Pr x.11 may be set at a higher resolution than the SinCos lines per revolution.</p> <ul style="list-style-type: none"> Encoder turns Pr x.09 <p>When an encoder with comms is used Pr x.09 must contain the number of bits in the comms message used to give the multi-turn information. For a single turn comms encoder Pr x.09 must be set to zero.</p>
Auto configuration	Enter: It is possible for the drive to set-up Pr x.09 , Pr x.11 and Pr x.10 automatically see Pr x.18
Set-up encoder lines per revolution	<ul style="list-style-type: none"> Equivalent lines per revolution Pr x.10
Error detection	Ensure: <ul style="list-style-type: none"> The required error detection is set-up in Pr x.17
Initialisation	Ensure: <ul style="list-style-type: none"> Position feedback is initialised Pr x.45 A re-initialise can be carried out enabling Pr 3.47

NOTE If SSI power supply bit monitor feature is enabled ensure that this has been configured in encoder setup parameters; Pr **x.09**, Pr **x.11**.

NOTE When using the above encoders Pr **x.46** lines per revolution divider should remain at 1 to ensure correct operation.

6.1.4 Comms only, absolute encoders

The following parameter set-up should be followed when configuring a Comms only absolute encoder.

Comms only absolute encoders, EndAt and SSI	
Before power-up	Ensure: <ul style="list-style-type: none"> Feedback device is connected Drive secure disable is not given (terminal 31)
Power-up drive	Ensure: <ul style="list-style-type: none"> Drive displays "inh" If the drive trips refer to Chapter 10 <i>Diagnostics</i> on page 98
Slot identification	Identify: <ul style="list-style-type: none"> Identify slot and associated menu, 15, 16, or 17
Select Solutions Module	Enter: <ul style="list-style-type: none"> Speed feedback selector Pr 3.26 1: Slot 1, 2: Slot 2, 3: Slot 3
Set-up encoder power supply	Enter: <ul style="list-style-type: none"> Encoder power supply Pr x.13 0: 5v, 1: 8v, 2:15v
Set-up encoder type	Enter: <ul style="list-style-type: none"> Encoder Type Pr x.15 8 (EndAt), 10 (SSI)
Set-up data format	Enter: <ul style="list-style-type: none"> SSI encoder format Pr x.18 (0 Gray code, 1 Binary format)
Auto configuration	Enter: <ul style="list-style-type: none"> EndAt, It is possible for the drive to set-up Pr x.09, Pr x.11 automatically see Pr x.18
Encoder comms	<ul style="list-style-type: none"> Encoder comms baud rate Pr x.14 (EndAt, SSI) Encoder comms resolution Pr x.11 <p>Where encoder comms is used for initial setting of the absolute position the comms resolution in bits must be set correctly.</p> <ul style="list-style-type: none"> Encoder turns Pr x.09 <p>When an encoder with comms is used Pr x.09 must contain the number of bits in the comms message used to give the multi-turn information. For a single turn comms encoder Pr x.09 must be set to zero.</p>
Error detection	Ensure: <ul style="list-style-type: none"> The required error detection is set-up in Pr x.17
Initialisation	Ensure: <ul style="list-style-type: none"> Position feedback is initialised Pr x.45 A re-initialise can be carried out enabling Pr 3.47

NOTE

If SSI power supply bit monitor feature is enabled ensure that this has been configured in encoder setup parameters; Pr **x.09**, Pr **x.11**.

6.1.5 Linear encoders

The following parameter set-up should be followed when configuring a linear encoder.

Linear encoders, Ab, SC, Ab.SERvo, SC.SERvo, SC.HiPEr, SC.EndAt, SC SSI, EndAt, SSI	
Before power-up	Ensure: <ul style="list-style-type: none"> Feedback device is connected Drive secure disable is not given (terminal 31)
Power-up drive	Ensure: <ul style="list-style-type: none"> Drive displays "inh" If the drive trips refer to Chapter 10 <i>Diagnostics</i> on page 98
Slot identification	Identify: <ul style="list-style-type: none"> Identify slot and associated menu, 15, 16, or 17
Select Solutions Module	Enter: <ul style="list-style-type: none"> Speed feedback selector Pr 3.26 1: Slot 1, 2: Slot 2, 3: Slot 3
Set-up encoder power supply	Enter: <ul style="list-style-type: none"> Encoder power supply Pr x.13 0: 5v, 1: 8v, 2:15v
Set-up encoder type	Enter: <ul style="list-style-type: none"> Encoder Type Pr x.15 0 (Ab), 6(SC), 3 (Ab.SERvo), 12 (SC.SERvo), 7 (SC.HiPEr), 9 (SC.EndAt), 11 (SC.SSI), 8 (EndAt), 10 (SSI) SSI encoder format Pr x.18 (0 Gray code, 1 Binary format)
Auto configuration	Enter: It is possible for the drive to set-up Pr x.09 , Pr x.10 , Pr x.11 automatically see Pr x.18
Set-up encoder lines per revolution	<ul style="list-style-type: none"> Equivalent lines per revolution Pr x.10 Calculate according to motor pole pitch and encoder resolution as follows $\text{Pr } x.10 = \text{Motor pole pitch} / \text{encoder resolution}$ <ul style="list-style-type: none"> Line per revolution divider Pr x.46 The equivalent lines per revolution Pr x.10 is divided by the value in Pr x.46 . This can be used when an encoder is used where the number of lines or sine waves per pole is not an integer e.g. 128.123 lines per rev = 128.123 in Pr x.10 and 1000 in Pr x.46 giving 128123/1000 = 128.123.
Encoder comms	<ul style="list-style-type: none"> Define linear encoder Pr x.16 = 0 Encoder comms baud rate Pr x.14 (EndAt, SSI) Encoder comms resolution Pr x.11 Pr x.11 must be set to the number of comms bits used to represent the whole encoder position in the comms message Encoder turns Pr x.09 When a linear encoder is selected no mask is placed on the turns information in Pr x.09 , this parameter displays the turns information as a full 16bit value. Linear SinCos encoders are normally specified with a length for each sine wave period and the length for the least significant bit of the position in the comms message. Pr x.09 should be set-up with the ratio between these two lengths: $\text{Pr } x.09 \text{ ratio} = \frac{\text{Length for a sine wave period}}{\text{Length of the LS bit of the position in the comms message}}$
Error detection	Ensure: The required error detection is set-up in Pr x.17
Initialisation	Ensure: Position feedback is initialised Pr x.45 A re-initialise can be carried out enabling Pr 3.47

NOTE When using the above incremental plus commutation, absolute encoders (Ab.SERvo, SC.SERvo) Pr **x.46** lines per revolution divider should remain at 1 to ensure correct operation.

6.2 Termination resistors

The encoder input termination resistors cannot be disabled when encoders with SinCos waveforms are selected. The Marker pulse input termination resistors cannot be disabled except when one of the following encoders is selected

Ab, Fd, Fr, Ab.SERVO, Fd.SERVO, Fr.SERVO.

By default the termination resistors on the encoder inputs are connected with the exception of the Marker pulse inputs which are disconnected. The termination resistors can be configured as shown below using encoder termination Pr x.16.

Terminal	Encoder Input	Pr x.16=0	Pr x.16=1	Pr x.16=2
1, 2	A, A\	Disabled	Enabled	Enabled
3, 4	B, B\	Disabled	Enabled	Enabled
5, 6	Z, Z\, Data, Data\	Disabled	Disabled	Enabled
7, 8, 9, 10, 11, 12	U, U\ V, V\ W, W\	Enabled	Enabled	Enabled

The termination resistance when connected (A, A\) = 120Ω total.

6.3 Simulated encoder outputs

Simulated Encoder Outputs				
	Type	Details	Output scaling	Update rate
Software Simulation	Ab Fd	When a marker is detected by the input source the marker position based on the non-marker reset position is transferred within 500µs. The simulator reacts in 250µs to a change in marker position sending out a change in position resulting from the marker correction. This change could be large when the first marker input is received. The simulator is limited to 500kHz, so many 250µs periods at maximum output frequency could be used if the position change is large. This system does not discard lines but could include a delay before the marker is output while the position change caused by the first marker input is output at the maximum output frequency. The marker is output as normal when the output position passes through zero.	Scaling available through both Pr x.25, Pr x.26	Source dependant e.g. Pr x.05 = 250µs Pr 3.29 = 250µs Pr x.30 = 4ms
	Ab.L Fd.L	When a marker is detected by the input source the marker position based on the non-marker reset position is transferred within 500µs. The simulator reacts to this change in marker position in the next 250µs period by sending a marker out in the next 250µs cycle at the same location in time within that cycle as the incoming marker was into the source. N.B. High A and B (or high F) alignment may alter the position. No pulses are discarded from the Ab / Fd outputs so that the relative speed delta is always correct. The device receiving the simulated encoder output signals can correct it's absolute position using the marker to become synchronised with the simulation source.		
	SSI Gray Code or Binary Format	The SSI output position is updated every 250µs, in binary or Gray SSI, with the start bit high and the power supply alarm bit (the last or lowest significance position bit) low. In SSI output the absolute position from the source is shifted, converted and then placed into a buffer, here it waits for an SSI master (clock signal) to transfer and decode the value. The baud rate for the simulated SSI encoder output is defined by the clock input from the external Master.	Shifting available through both Pr x.47 and Pr x.48	
Hardware Simulation	H.int H.drv	The drive or Solutions Modules incremental encoder inputs are routed directly through to the simulated encoder output terminals through hardware.	Scaling not possible	Minimal due to hardware simulation approx 100ns

Output initialisation

During power-up the source position may not be valid. The simulator will wait until the position feedback source has been initialised before using the current position as the first output position. As a result the SSI output will be held high until the source has been initialised which will trigger the master to trip on power supply failure. Once initialised the simulator will not stop even if the source device is re-initialised or trips.

NOTE If the source is not feedback device, the simulator waits until all feedback device sources have initialised before the starting to output. The wait for initialisation does not occur if the drive software version is less than **V01.08.00**

NOTE For more detailed information on the simulated encoder output details and set-up refer to the following sections.

NOTE The above simulated encoder outputs are not available when the source encoder connected to the SM Universal Encoder Plus is one of the following, Ab.SERvo, Fd.SERvo, Fr.SERvo, or SC.SERvo. This is due to the commutation inputs from these encoders using the same I/O ports as the simulated encoder output.

NOTE The simulator used to generate the simulated encoder output updates at a rate of 250µs, if a source is selected for the simulated encoder output which updates at a much slower rate, for example 4ms, averaging will be applied to the simulated encoder output to prevent "stepping" effects being seen.

NOTE The simulated encoder outputs available on terminal PL1 are identical to the simulated encoder outputs available on terminal SK2 (internally connected)

NOTE At default the simulated encoder output is set-up to give a 4096 line output (Pr **x.25** = 0.2500 and Pr **x.26** = 1.000).

The simulated encoder outputs can be generated from either of the following sources, through configuration of Pr **x.24**.

- SM-Universal Encoder Plus positional information.
- Any parameter, which has a 16-bit position value in the form of a roll-over counter (parameters with a range of -32768 to 32767 or 0 to 65535) or any parameter/ value which has a 32 bit position value in the form of a roll over counter for SSI.

The simulated encoder output mode can be configured with Pr **x.28** to be either of the following types.

Terminals	Mode	Output	Pr x.28
SK2 7, 8, 9, 10	Quadrature	Ab	0
	Frequency and Direction	Fd	1
	SSI output, Gray code	SSI Gray	2
PL1 3, 4, 5, 6	SSI output, Binary format	SSI Binary	3
	Quadrature with marker LOCK	Ab.L	4
	Frequency and direction with marker LOCK	Fd.L	5
	Drive ABZ inputs routed directly to the simulated encoder output through hardware	H.drv	6
	Solutions Modules ABZ input routed directly to the simulated encoder output through hardware	H.int	7

H.drv and H.int are only available with drive software version **01.07.00** onwards.

In order to set-up the scaling of the simulated encoder output both the numerator Pr **x.25** and denominator Pr **x.26** should be set-up taking into consideration the source parameter defined in Pr **x.24**.

Example:

Simulated encoder output source = Pr **3.29** main encoder feedback (65536 - 16 Bit)

The ratio for a simulated encoder output of 1024 lines (4096) is (Pr **3.29**) 65536 / (Enc cpr) 4096 = 16

Therefore to set-up a simulated encoder output of 1024 lines, the scaling has to be set to a ratio of 1/16, parameter settings being: Pr **x.24** = Pr **3.29**, Pr **x.25** = 0.1, Pr **x.26** = 1.6 and Pr **x.28** = 0 (Ab).

Or the following parameter settings can be used:

Source	Encoder output	Pr x.25	Pr x.26
65536	4096	4096	1.6384
	2048	2048	
	1024	1024	
	512	512	
	256	256	

Source - 65536 rollover parameter e.g Pr **3.29**, Pr **x.05**.

Encoder output - the encoder output resolution can be higher than the encoder connected to the source, however quantisation effects need to be taken into consideration, e.g 1 count on source may equal 10 on simulated output.

NOTE

The simulated encoder output simulator has no information regarding the lines per revolution of the source for the simulated encoder output. Instead, it treats this position as a 16 bit or 24 bit number with roll-over / roll-under.

6.3.1 Simulated encoder source resolution

16-bit

The encoder output resolution at default will be 16-bit (source parameters range -32768 to 32767 or 0 to 65535) however this can be increased to 24-bit as detailed below.

24-bit

When using a high precision encoder as feedback i.e. SinCos, SSI or EndAt and the source parameter, Pr **x.24** has been selected as Pr **x.05** position, the encoder output resolution can only then be increased from 16-bit to a 24 bit position value by setting Pr **x.27** encoder simulation resolution.

6.3.2 Software simulation: high resolution encoder

This situation occurs when the source parameter is Pr **x.05** (Position) of the same module, the source device is a high precision encoder i.e. Comms only, and the simulated encoder output is Ab or Fd and Pr **x.27** encoder simulation resolution is selected.

The position Pr **x.05** and fine position Pr **x.06** are read every 250µs with the output being generated during the next period. This gives a simulated encoder output of the main encoder with higher resolution (24 bit). The output position is defined as follows.

$$\text{Output position} = \text{Counted input position} \times (\text{Pr } \mathbf{x.25} / \text{Pr } \mathbf{x.26})$$

Example:

in order to simulate one to one with a 13 bit (8192 count) comms only encoder resolution. (The current position is taken in 16777216^{ths} of a revolution (24 bit)). The ratio down to 8192 pulses requires 1/2048, or 0.0001/0.2048. So Pr **x.25** = 0.0001 and Pr **x.26** = 0.2048.

6.3.3 Software simulation: any other condition

If the source parameter is not as described above the parameter will be read every 250µs and the output generated during the next period under software control within the Solutions Module. The output position is defined as follows.

$$\text{Output position} = \text{Parameter value} \times (\text{Pr } \mathbf{x.25} / \text{Pr } \mathbf{x.26})$$

NOTE

The source parameter's update rate should be taken into consideration. If the source parameter has a 4ms update rate, this will result in a block of output pulses in 250µs and then 3.75ms of no pulses. Due to this if the source is for example a 4ms update averaging will be applied to the simulated encoder output preventing "stepping" effects being seen.

6.3.4 Simulated encoder output SSI

NOTE

The position in the simulator is updated every 250µs, this being determined by the drive and SM-Universal Encoder Plus software and not the master.

In SSI output mode the absolute position from the source is shifted, converted and then placed in a buffer to await for an SSI master to transfer and decode the value. The output can be binary or Gray code. There is no scaling. The source (directed by Pr **x.24**) can be of three types:

- Position from a feedback device, Pr **3.29** of the drive or Pr **x.05**, SM-Universal Encoder Plus or a SM-SLM which can be corrected by the device's marker if this is enabled. This can be up to 16 turn bits and 32 position bits value.
- A 32 bit user parameter (range of -2^{31} to $2^{31} - 1$ or 0 to 4,294,967,295) which can be split between the turns and position bits. The data is taken from the most significant part of the source parameter.
- A 16 bit user parameter (range of -32768 to 32767 or 0 to 65535) which can be split between the turns and position bits. The data is taken from the most significant part of the source parameter.

The SSI is an absolute encoder so if possible the position will be synchronised to the source's full position. If the source is the drive position (Pr **3.29**) or any SM-Universal Encoder Plus option module (Pr **x.05**), and source's marker reset is not disabled (Pr **3.31** = 0, or Pr **x.07** = 0), the source will become synchronised to the marker reset position.

If the position source is the drive, SM Universal Encoder Plus or an SM-SLM, Pr **x.47** (the SSI output turns) and Pr **x.48** (the SSI output resolution) are used to construct the SSI output position which is updated every 250µs. The position is in Binary format, or Gray code SSI with the start bit high and the power supply alarm bit (the last or lowest significance position bit) low.

If the source is a 32 bit user parameter, the most significant M bits will be used as the SSI output string, where M is the total of the turns and position bits set in Pr **x.47** and Pr **x.48**. The same applies for a 16 bit source. The master can transfer up to 49 bits (the start high bit and 48 bits of data including the power supply alarm low bit). The source parameter data will be the most significant part and the rest of the data will be packed with zeros. The position is in Binary format or Gray code SSI with the start bit high and the power supply alarm bit (the last position bit) low.

It must be remembered that the Solutions Module acts as a slave and is clocked by the master device. As the position is updated synchronised to the drive, this position will not be synchronised to the master.

The Solutions Module detects the end of a transfer when the master pauses the clock for more than 90µs. During this time the SSI interface resets and prepares for the next transfer. The baud rate is set in the master device, but the Solutions Module can output up to 500kHz. The pause time of 90µs must never be reduced. Invalid data transfer can occur if the pause length is reduced below 90µs (must not pause for > 20µs).

The SM-Universal Encoder Plus simulated output may require a longer time to initialise than the encoder input port, on a SM-Universal Encoder, Drive or an external receiver.

The power failure bit will be set by the simulating SM-Universal Encoder Plus until it is ready. If the simulating SM-Universal Encoder Plus and the receiver connected to it are powered-up simultaneously, the receiver may fail to initialise due to the power failure bit. The user must then re-initialisation the receiver (using Pr 3.47 if a drive is the receiver) now the simulating SM-Universal Encoder Plus is ready.

Example:

Figure 6-1 shows the Clock (master), which is configured for 24 bits of information and the simulated data output from the Solutions Module. The simulated data output from the Solutions Module can be seen from two requests. Request 1 is shown as position 1 with this being zero, then there is the required interval of 90µs, request 2 = position 2 with this now being 4194305.

The Solutions Module detects the end of a transfer when the master pauses the clock for more than 90µs.

NOTE The position in the simulator is updated every 250µs; this being determined by the drive and SM-Universal Encoder Plus software and not the master.

Figure 6-1 24 bit simulated SSI encoder output

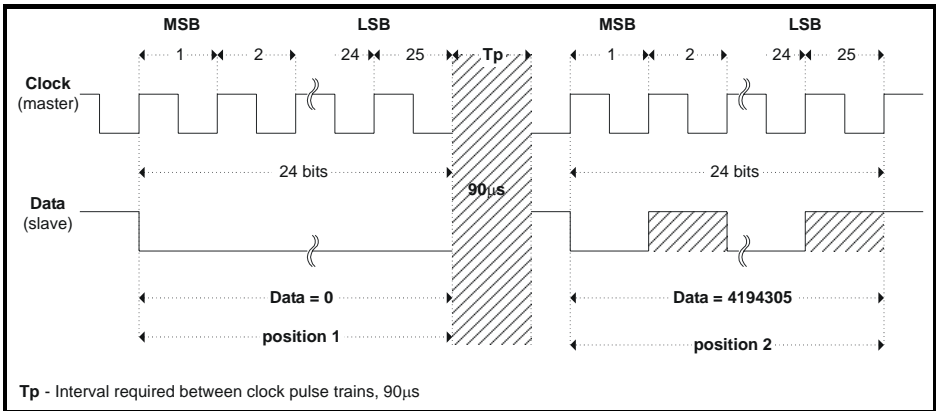

During this time the SSI interface resets and prepares for the next transfer. The baud rate is set in the master device, but the Solutions Module can output up to 500kHz. **The pause time of 90µs must never be reduced.**

A typical drive source example is given below:

The SSI output turns Pr x.47 are set to the maximum, 16 and the SSI output resolution Pr x.48 is set to its maximum, 32 to produce the full 48 bit multi-turn position (the start/latching bit is added to this to give 49 bits that will be transferred). The master is set up for this also, and its clock rate is set at 400kHz. The master transfers a position value every 250µs.

At 400kHz, the transfer takes 122.5µs. As the next transfer will be 127.5µs later the pause condition is satisfied. If the clock were to be reduced to 300kHz, the pause time would be less than 90µs so the communication channel could not be guaranteed.

Figure 6-2 SSI data transfer at maximum resolution and 300 / 400 kHz clock frequency

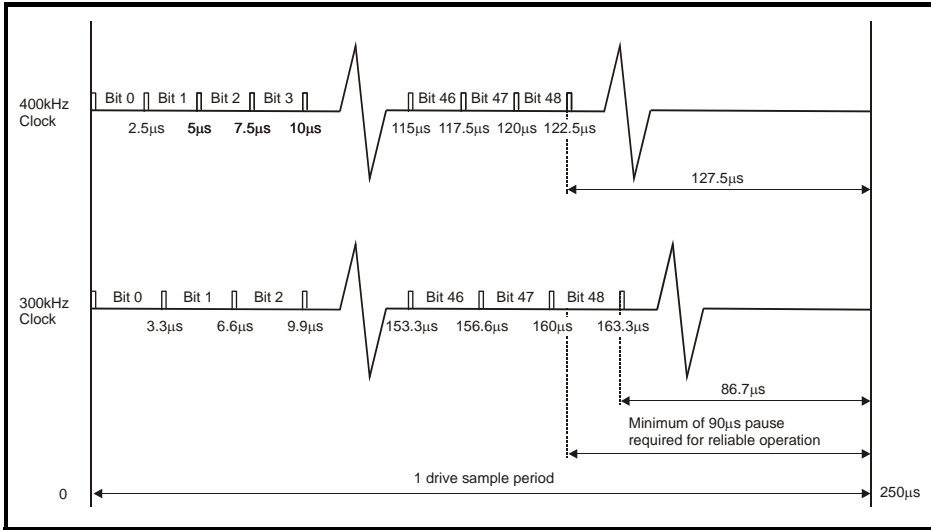

A typical 32-bit source parameter example is given below:

The master controls the number of bits transferred and how many of the bits are the turn's information. For example a 32-bit parameter could contain 8 bits of turn information as the most significant part, and 10 bits of positional information as the next significant part. The bit string is shown below:

31	24	23	14	13	0
Turns information		Position		Do not care	

The master is set to transfer 18 bits (plus one for the start/latch). The least significant bit sent will be forced low to indicate that the power supply is fine. The master is also set to take the most significant 8 bits as the turns information. The user is responsible for preparing the source parameter.

Output initialisation

During power-up the source position may not be valid. The simulator will wait until the position feedback source has been initialised before using the current position as the first output position. As a result the SSI output will be held high until the source has been initialised which will trigger the master to trip on power supply failure. Once initialised the simulator will not stop even if the source device is re-initialised or trips.

NOTE

If the source is not feedback device, the simulator waits until all feedback device sources have initialise before the starting to output. The wait for initialisation does not occur if the drive software version is less than **V01.08.00**

6.4 Marker inputs

A marker channel input is only optional when operating with either of the following incremental encoders:

Ab	Ab.SErvo
Fd	Fd.SErvo
Fr	Fr.SErvo

When the marker channel input becomes active this can be used to

1. Reset the encoder position Pr **x.05** and Pr **x.06** and set the marker flag Pr **x.08** (Pr **x.07** should = 0)
2. Set the marker flag Pr **x.08** (Pr **x.07** should = 1)

When the position is reset by the marker channel input, Pr **x.05** and Pr **x.06** are reset to zero. The marker flag is set each time the marker input becomes active, but it is not reset by the drive, and so this must be done by the user.

Marker reset data

Each time the marker becomes active the non-marker position values in Pr **x.29** revolution counter Pr **x.30** position and Pr **x.31** fine position are sampled and stored in Pr **x.32** marker revolution counter, Pr **x.33** marker position and Pr **x.34** marker fine position.

Non marker reset data

Pr **x.29**, Pr **x.30**, and Pr **x.31** positional information is taken from the position feedback device with these not being affected by the marker inputs.

6.5 Marker outputs

A simulated marker output is available (Pr **x.38**) with either Fd, Fd.lock, Ab or Ab.lock, H.drv or H.int as the simulated encoder output mode (Pr **x.28**) and a simulated encoder output source has been defined (Pr **x.24**).

The marker pulse is simulated if the marker output port is not being used for the RS485 freeze input with the marker being synchronised with the zero count, and the duration is calculated from the current position (taken every 250µs) and the change in position.

The marker is output when both the A and B quadrature signals or F frequency is high (when the source defined in Pr **x.24** reaches 0).

If the source is the drive position (Pr **3.29**) or any SM-Universal Encoder Plus (Pr **x.05**), and the source's marker reset is enabled (Pr **3.31** = 0, or Pr **x.07** = 0), the source will become synchronised to the marker reset position:

In AB or FD modes (normal marker synchronisation):

When a marker is detected by the input source (the drive or SM-Universal Encoder Plus) the marker position based on the non-marker reset position is transferred within 500µs.

The simulator reacts to this change in marker position in the next 250µs period by sending out the change in position resulting from the marker correction. This change could be large when the first marker input is received by the source. The simulator is limited to 500kHz, so many 250µs periods at maximum output frequency could be used if the position change is large. The marker is output as normal when the output position passes through zero.

This system does not discard lines but could include a delay before the marker is output while the position change caused by the first marker input is output at the maximum output frequency.

NOTE High A and B (or high F) alignment may alter the position.

In AB.L or FD.L modes (marker lock):

When a marker is detected by the input source (the drive or SM-Universal Encoder Plus) the marker position based on the non-marker reset position is transferred within 500µs.

The simulator reacts to this change in marker position in the next 250µs period by sending a marker out in the next 250µs cycle at the same location in time within that cycle as the incoming marker was into the source.

NOTE High A and B (or high F) alignment may alter the position.

No pulses are discarded from the Ab/Fd outputs so that the relative speed delta is always correct.

The device receiving the simulated signals can correct it's absolute position using the marker to become synchronised with the simulation source.

Output initialisation

During power-up the source position may not be valid. The simulator will wait until the position feedback source has been initialised before using the current position as the stored last position. This in turn makes the initial output delta equal to zero during the first simulator output cycle. As a result there will be no output pulses to move from zero (the reset value of the stored last position) to the initial position of absolute encoder sources. Once initialised the simulator will not stop even if the source device is re-initialised or trips.

NOTE If the source is not feedback device, the simulator waits until all feedback device sources have initialise before the starting to output. The wait for initialisation does not occur if the drive software version is less than **V01.08.00**

6.5.1 Configuration

Parameter setup

1. Define source in Pr **x.24** simulated encoder source
2. Using Pr **x.38** configure terminals 8 and 9 on connector PL1 for marker output

NOTE In order to have the marker pulse synchronised to the falling edge of the encoder output the encoder input signals on terminals 1, 2, 3, and 4 have to be reversed (e.g. A with A\ and B with B\).

6.6 Freeze inputs

NOTE Limitations apply if the drive software version is later than **V01.07.00**, refer to Pr **x.38** description (limited freeze inputs).

NOTE Any unused freeze inputs when operating with another freeze input should be held in a low condition to prevent spurious/incorrect operation of the freeze. If multiple freeze inputs are connected, the freeze will operate as an OR function.

6.6.1 Configuration

If a freeze input of 24V or RS485 is to be used to freeze more than one SM-Universal Encoder Plus, the freeze drive/slot bus input should be selected with Pr **x.38**.

When Pr **x.41** = 0 freeze occurs on the rising edge of the freeze input and when Pr **x.41** = 1 freeze occurs on the falling edge of the freeze input.

The selection of which freeze input is used is dependent upon the value of Pr **x.38**. The selection of the freeze inputs are as shown following. The default is 1 that corresponds to only the 24V input.

The freeze input can take the form of either

1. A 485 signal on terminals 8 and 9 of PL1
2. A 24V signal on the freeze 24V input on terminal 1 of PL1
3. A signal on the internal drive and slot freeze line generated by another Solution Module.

Pr x.38	24V input	485 input	Drive / Slot bus input
0	No	No	No
1	Yes	No	No
2	No	Yes	No
3	Yes	Yes	No
4	No	No	Yes
5	Yes	No	Yes
6	No	Yes	Yes
7	Yes	Yes	Yes

Freeze data

Each time the freeze input to the Solutions Module becomes active the non-marker position Pr **x.29** revolution counter Pr **x.30** position and Pr **x.31** fine position are stored in Pr **x.35** freeze revolution counter Pr **x.36** freeze position and Pr **x.37** freeze fine position and the freeze flag Pr **x.39** is set.

The freeze flag Pr **x.39** is not reset by the module and must be reset by the user, if not reset no other freeze conditions will be stored.

When a freeze occurs on the Solutions Module the main drive slot can also be stored if Pr **x.40** *Freeze main drive other slots* is set to one.

6.6.2 Freeze input with SM-Applications

Whenever a SM-Applications and a SM-Universal Encoder Plus are used, the freeze input can be connected to either the SM-Universal Encoder Plus and Pr **x.40** *Freeze main drive other slots* set or connected to the SM-Applications.

NOTE For SM-Applications, also refer to Pr **90.47** and Pr **90.48** *Enable freeze flag*.

Figure 6-1 SM-Universal Encoder Plus to SM-Applications freeze transfer

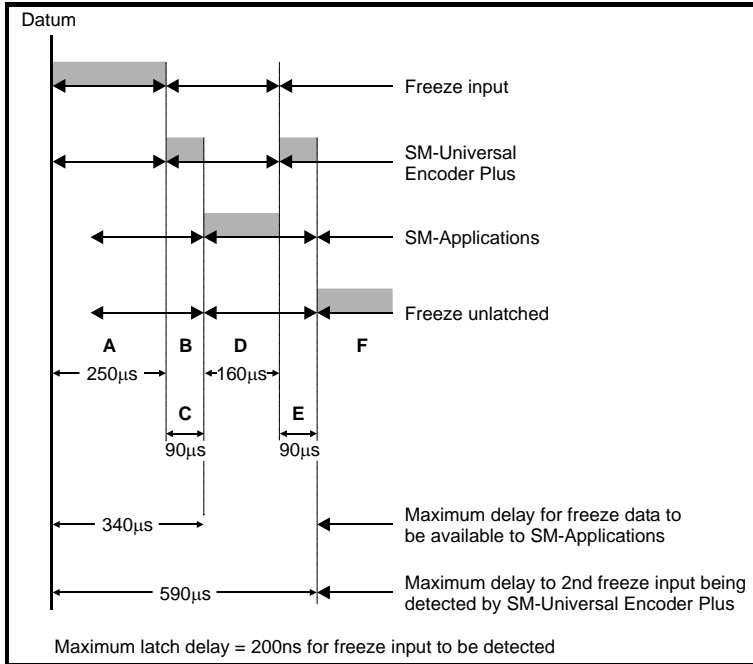

A	Freeze input active anywhere within 250µs
B	Freeze positional data available in SM-Universal Encoder Plus
C	90µs delay before SM-Applications can use data
D	Data available for SM-Applications, plus freeze unlatch sent to SM-Universal Encoder Plus
E	Freeze input unlatched anywhere with 90µs by SM-Universal Encoder Plus
F	Freeze input unlatched

6.6.3 Freeze input with SM-Encoder Plus and SM-Resolver

Before consecutive freeze operations can be performed in the SM-Encoder Plus or SM-Resolver, the SM-Universal Encoder Plus freeze flag (Pr **x.39**), or SM-Applications freeze flag (Pr **90.18** and Pr **90.28**) must be cleared together with the SM-Encoder Plus and SM-Resolver freeze flag (Pr **x.39**).

6.7 Thermistor input

The SM-Universal Encoder Plus has a thermistor input which will allow connection of a motor thermistor (as with the Unidrive SP drive)

x.12		Motor thermistor check enable							
RW	Bit							US	
↕	OFF (0) or On (1)				⇒	OFF (0)			
Update rate: Background read									

This bit should be set if a motor thermistor is connected to the SM-Universal Encoder Plus Solutions Module. The Solutions Module will trip for both

- Over temperature
- Thermistor short circuit.

Trip	Pr x.50
Thermistor trip	9
Thermistor short circuit	10

The thermistor must have a positive temperature gradient.

For a resistance less than 50 Ω a short-circuit trip will occur.

For a resistance greater than 3k3 Ω an over temperature trip will occur. The trip will not be permitted to be reset unless the resistance reduces to below 1k8 Ω or Pr **x.12** is returned to 0 to disable the motor thermistor check.

x.21		Feedback reference/ motor thermistor resistance							
RO	Bi					NC	PT		
↕	-100.0 to +100.00%				⇒				
Update rate: 4ms write									

The resistance value of the thermistor input can be seen in Pr **x.21**. The motor thermistor resistance value shown in Pr **x.21** is shown in 0.1% of 10k Ω units.

If the feedback reference is being used (Pr **x.23**) then Pr **x.21** becomes the feedback reference and takes priority over the motor thermistor resistance indication.

7 Encoder feedback positional information

7.1 Encoder feedback positional information

The encoder feedback in the SM Universal Encoder plus option module can consist of the following positional information. The positional information available being determined by the encoder feedback device used.

1. Revolutions
2. Position
3. Fine position

The encoder feedback parameters effectively give the position with a resolution of 1/232ths of a revolution, as a 48bit number as shown below:

47	32 31	16 15	0
Revolutions	Position	Fine position	

The position is always converted to units of 1/232ths of a revolution, but some parts of the value may not be relevant depending on the resolution of the feedback device.

For example a 1024 line digital encoder produces 4096 counts per revolution (12bit), the position is represented as shown below (bits in shaded area only).

47	32 31	20 19	16 15	0
Revolutions	Position		Fine position	

If a linear encoder is used the turns information is used to represent movement by the number of poles defined by Pr 5.11. Therefore if the number of poles is set to two, one revolution is the movement by one pole pitch.

This positional information available inside the SM Universal Encoder Plus option module is located in three "parameter sets" as follows:

1. **Marker reset position** information [Pr x.32, Pr x.33, Pr x.34] each time the marker input becomes active the non-marker reset position values, Pr x.29, Pr x.30 and Pr x.31 are sampled and stored here. If there is no marker input these parameters are not applicable.
2. **Non - marker reset position** information [Pr x.29, Pr x.30, Pr x.31] this position is taken from the encoder feedback device and is not affected by either the marker or freeze inputs.
3. **Position information** [Pr x.04, Pr x.05, Pr x.06] each time the marker input becomes active this position is updated with the "non marker reset position" minus the "marker reset position" (the revolution positional information Pr x.04 is unaffected). If the marker position disable Pr x.07 is selected, or there is no marker input, then the position information [Pr x.04, Pr x.05, Pr x.06] is equal to the non-marker reset position.

Dependent upon the encoder type used the position information representation can change as detailed following:

Incremental encoder

- The non-marker reset position is the relative position of the encoder and is not modified by a marker input.
- The marker reset position information is updated every time a marker input is detected

- Positional information = non-marker reset position - the marker position.
- The non-marker reset position (relative) is used as the control position internally by the drive.

SinCos, Comms, SinCos plus comms encoder

- Due to there being no marker input with these encoders the non-marker reset position = position information.
- The marker reset position is not applicable
- The non-marker reset position (relative) is used as the control position internally by the drive.

Incremental or SinCos plus commutation

- The non marker reset position is the relative position of the encoder and is not modified by a marker input
- Marker reset positional information is updated every time a marker input is detected
- Positional information is the non marker reset position minus the marker position
- The control position in this case is the non marker reset position minus the offset generated from the commutation signals during the synchronisation (first 60° to 120°), this position is only available internally and cannot be viewed in any parameter.

Figure 7-1 Encoder position flow diagram

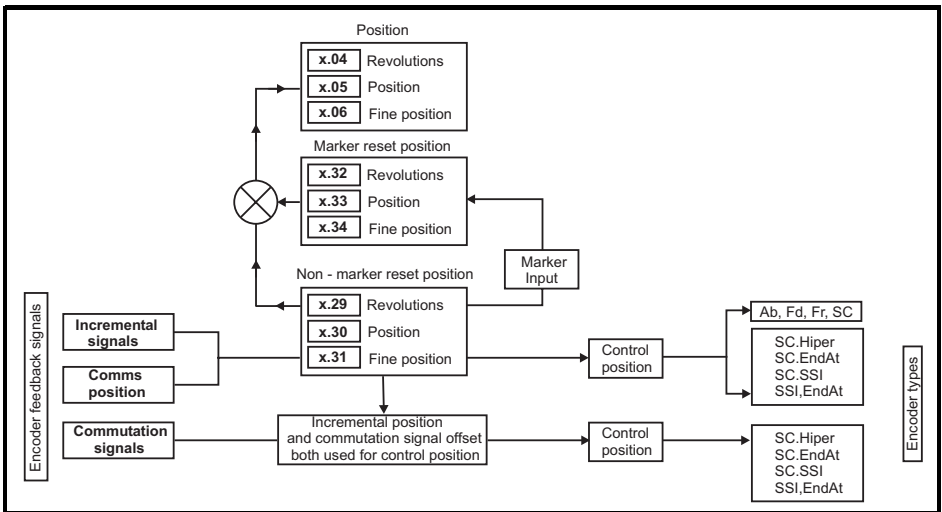

8 Advanced Operation

8.1 Serial communications

NOTE

At power-up Pr **x.45** is initially zero, but is set to one when the encoder connected to the Solutions Module has been initialised. The drive cannot be enabled until Pr **x.45** is one.

If the encoder power-supply is lost, or the encoder type Pr **x.15** is changed for an encoder connected to a Solutions Module, and the encoder type is SC, SC.HiPEr, SC.EndAt or EndAt the encoder will no longer be initialised.

When an encoder is no longer initialised Pr **x.45** is reset to zero and the drive cannot be enabled.

The encoder may be re-initialised, provided the drive is not active, by setting Pr **3.47** to one. Pr **3.47** is automatically reset to zero when the initialisation is complete.

8.1.1 SinCos

Encoder Comms Resolution

Where encoder comms is used for initial setting of absolute position (SC.HiPEr or SC.EndAt), the comms resolution in bits must be set correctly, either by the user in Pr **x.11** or the Solutions Module automatically (see Pr **x.18**). The comms resolution may be higher than the resolution of the sine waves per revolution.

Encoder Comms Baud Rate

The SinCos encoder comms baud rate is fixed at 9600 baud when using a Stegmann Hiperface encoder (Pr **x.14** encoder comms baud rate has no effect.)

Any baud rate can be used when encoder comms is used with a SinCos encoder to obtain the absolute position during initialisation, as long as this is within the encoder's specification.

Encoder Turns

When an encoder with comms is used, Pr **x.09** must contain the number of bits in the comms message used to give the multi-turn information. For a single turn comms encoder Pr **x.09** must be set to zero. It is possible for the drive to set up this parameter automatically from information obtained from the encoder via Hiperface or EndAt interfaces during auto configuration.

Encoder Position Check

If Pr **x.44** is set to one, position checking is disabled and encoder comms is available via the transmit and receive registers. The transmission system can be used to communicate with encoders provided the mode is SC.HiPEr or SC.EndAt as follows:

For both comms protocols more than one byte of data must be written to the transmit register or read from the receive register during the transfer of one message. Bits 13-15 are used to indicate the following:

Register	Bit	Function
Transmit	15	Must be set for the Solutions Module to transfer the LS byte to the comms buffer.
Transmit	14	The LS byte is the last byte of the message and this byte should be put in the comms buffer and be transferred to the encoder.
Transmit	13	The LS byte is the first byte of the message. (If this is used the buffer pointer is reset to the start of the buffer.)
Receive	15	Indicates data from the last transfer can be read from the receive buffer.
Receive	14	The byte in the LS byte is the last byte of the receive message
Receive	13	There is no data in the receive buffer and the LS byte is the comms system status. If there was an error in the received message this will always be set and one of the status error bits will be set until the comms is used again by this system.

Data should be written to the transmit buffer when the buffer has been reset to zero by the module. The data will be transferred to the comms buffer and the transmit register will be cleared. Data can be read from the receive buffer at any time. If there is receive data in the buffer bit 15 will be set. Once the data has been read the buffer should be cleared and the module will then transfer more data. The buffer is 16 bytes long and any messages that exceed this length (including the checksum added for Hiperface) will cause an error. The status flags are defined as follows:

Bit	Meaning
0	The number of bytes put into the transmit buffer is not consistent with the expected message length.
1	The number of bytes written to the transmit buffer, or the expected length of the store data transmit message, or the expected length of a read data message have exceed the length of the buffer.
2	The command code is not supported.
3	The encoder has signalled an error.
4	There was an error in the checksum/CRC of the received message.
5	A timeout occurred.
6	The last message was to auto-configure the drive encoder and the encoder was identified successfully.
7	The last message was initiated through the Solutions Module interface or from the drive electronic nameplate system and the last message was successful.

SC.HiPEr

The Stegmann Hiperface comms protocol is an asynchronous byte based system. Up to 15 bytes of data can be written to the buffer. The first byte should be the encoder address. The checksum will be calculated by the module and added to the end of the message before the message is transmitted to the encoder. The module checks the checksum of the received message. If successfully received, the receive message can be read via the receive register including the address and the checksum received from the encoder. It should be noted that the encoder must be set up for 9600 baud, 1 start bit, 1 stop bit and even parity (default set-up) for the encoder comms to operate with the module. Also the data block security should not be enabled if the SM-Encoder nameplate system is to operate correctly.

The following commands are supported:

Code	Command
0x42	Read position
0x43	Set position
0x44	Read analogue value
0x46	Read counter
0x47	Increment counter
0x49	Clear counter
0x4a	Read data (maximum of 10 bytes)
0x4b	Store data (maximum of 9 bytes)
0x4c	Data field status
0x4d	Create a data field
0x4e	Available memory
0x50	Read encoder status
0x52	Read type

Example of a SC.HiPEr positional data transfer via serial comms

Requesting the position from a SC.HiPEr encoder (12/14 = Turns/Position).

Pr **x.44** has to be set to a one (encoder comms set-up for transmit / receive registers Pr **x.42** and Pr **x.43**) to open the parameter channels. For position, only two bytes need to be sent from the SM-Universal Encoder Plus, the address and command being 0x42 (hex). For simplicity the address is chosen as the broadcast address 0xFF, which can be seen by encoders of any address.

The 16-bit word to be placed through drive serial comms, or a SM-Applications, is made up of a transfer command byte (the highest byte) and the data to be transferred (the least significant byte). To alert the SM-Universal Encoder Plus to the fact that there is new data in Pr **x.42**, the most significant bit of the transfer command byte (bit 15 of the full word) must be set. To alert the SM-Universal Encoder Plus that this is the first byte to be transferred, bit 13 of the full word should be high. The first byte to be sent is the address, so the full word to be placed in Pr **x.42** is below in binary:

```

Most significant end
1010      0000      : 1111      1111
Transfer Command : Data to transfer
0xa0      :          0xff
Gives the decimal number 41215.

```

Once placed into Pr **x.42**, the parameter will be read by the option and its value returned to zero to signify that the next word can be entered. This is the last byte required to send (as the option will add the checksum) so bit 15 and bit 14 of the full word must be set. The data byte to be sent is the read position command 0x42. The last byte to be sent is the Hiperface command, so the full word to be placed in Pr **x.42** is below in binary:

```

Most significant end
1100      0000      : 0100      0010
Transfer Command : Data to transfer
0xc0      :          0x42
Gives the decimal number 49218.

```

Once placed into the Pr **x.42**, the parameter will be read by the SM-Universal Encoder

Plus and its value returned to zero to signify that the data has been sent. Next the receive register, Pr **x.43** should be read. If the most significant bit is high (if the value is \geq than 32768) new data has been placed there by the SM-Universal Encoder Plus. This data should be read by the user and then Pr **x.43** should be set to zero by the user to alert the option that the next word should be placed into this parameter.

In this particular example the position with SinCos interpolation according to Pr **x.04** and Pr **x.05** was turn 3429 and position 36446. The position requires dividing by 8 to produce a 14-bit position as will be given from the read position data transfer, this gives a position of 9112. The returned data from the encoder and read through Pr **x.43** is given in the following table:

Word number	Returned value	Returned value in hex.	Data in decimal	Data in hex.	Data in binary
1	32832	0x8040	64	0x40	0100 0000
2	32834	0x8042	66	0x42	0100 0010
3	32771	0x8003	03	0x03	0000 0011
4	32857	0x8059	89	0x59	0101 1001
5	32867	0x8063	99	0x63	0110 0011
6	32919	0x8097	151	0x97	1001 0111
7	49324	0xc0ac	172	0xac	1010 1100

All the returned values have been offset by 32768 which is the most significant bit. The last byte has an addition offset of 16384 to denote that it is the last byte.

First check the CRC (which is also checked by the Solutions Module), this is the XOR of all the data bytes before bit position by bit position, for example the least significant bit of the CRC is zero as the XOR (001111) is zero.

Words 3 to 6 are the position with the least significant bit as the least significant bit of word 6 so any unused bits being placed in the more significant part of word 3. Below are the numbers laid out in the correct order:

Word 3	Word 4	Word 5	Word 6
3	89	99	151
0000 0011	0101 1001	0110 0011	1001 0111

Shifted to turns and position (which is 12-bits then 14-bits):

1101 0110 0101	10 0011 1001 0111
(end of turns and start of the position)	
3429	9111

So the absolute position is 3429/9111 which should be compared to the displayed interpolated position of 3429/9112.

SC.EndAt

The Heidenhain EndAt protocol is a synchronous protocol using the following message format.

Command	1 st byte
Address	
Data (LSB)	4 th byte
Data (MSB)	

The following commands are supported:

Code	Command	Address	Data
0x00	Encoder to send position	Don't care	Don't care
0x01	Selection of memory area	MRS code	Don't care
0x03	Encoder to receive parameter	Address	Data
0x04	Encoder to send parameter	Address	Don't care
0x05	Encoder to receive reset	Don't care	Don't care

The following is an example of the response when the encoder to send position command is used.

LS byte	1 st byte	Bit 7-0 = 0
		Bit 7-0 = 0
		Bit 7-0 = 0
		Bit 7-0 = 0
		Bits 5-0 = 0
		Bit 6 = Alarm bit
		Bit 7 = Bit 0 of position
	Bits 7-0 = Bits 8-1 of position	
	Bits 3-0 = Bits 12-9 of position	
	Bits 7-4 = Bits 3-0 of turns	
MS byte	8 th byte	Bits 7-0 = Bits 11-4 of turns

The example shown above is for an encoder with 12 bits representing the turns and 13 bits representing the position within a turn. The position command only requires one byte to be sent to the encoder. Bits 14 and 13 can both be set in the transmit register to indicate that this is both the first and last byte of the message.

If any other command is used then the response is as follows:

Address	1 st byte
Data (LSB)	
Data (MSB)	3 rd byte

Example of a SC.EndAt positional data transfer via serial comms

Requesting the position from a SC.EndAt encoder (12/13 = Turns/Position).

To request the position the following data output must be sent:

Command = 0x00	1 st byte
Address = not needed = 0x00	
Data (LSB) = not needed = 0x00	
Data (MSB) = not needed = 0x00	4 th byte

The 16-bit word to be placed through drive serial comms, or a SM-Applications, is made up of a transfer command byte (the highest byte) and the data to be transferred (the least significant byte). To alert the SM-Universal Encoder Plus to the fact that there is new data in Pr **x.42**, the most significant bit of the transfer command byte (bit 15 of the full word) must be set. To alert the SM-Universal Encoder Plus that this is the first byte to be transferred, bit 13 of the full word should be high. The first byte to be sent is the command, so the full word to be placed in Pr **x.42** is below in binary:

Most significant end
 1010 0000 : 000 0000
 Transfer Command : Data to transfer
 0xa0 : 0x00
 Gives the decimal number 40960.

Once placed into Pr **x.42**, the parameter will be read by the SM-Universal Encoder Plus and its value returned to zero to signify that the next word can be entered.

The next two words only require the most significant bit to be high:

32768
 32768

Once placed into the Pr **x.42**, the parameter will be read by the SM-Universal Encoder Plus and its value returned to zero to signify that the next word can be entered. This is the last byte required to send so bit 15 and bit 14 of the full word must be set. The data byte to be sent is the read position command 0x42. The last byte to be sent is the most significant byte of data, so the full word to be placed in x.42 is below in binary:

Most significant end
 1100 0000 : 0000 0000
 Transfer Command : Data to transfer
 0xc0 : 0x00
 Gives the decimal number 49152.

Once placed into the Pr **x.42**, the parameter will be read by the option and its value returned to zero to signify that the data has been sent. Next the receive register Pr **x.43** should be read. If the most significant bit is high (if the value is equal to or higher than 32768) new data has been placed there by the SM-Universal Encoder Plus. This data should be read by the user and then the Pr **x.43** should be set to zero by the user to alert the SM-Universal Encoder Plus that the next word should be placed into this parameter.

In this particular example the position with SinCos interpolation according to Pr **x.04** and Pr **x.05** was turn 1860 and position 59887. The position requires dividing by 16 to produce a 13-bit position as will be given from the read position data transfer, this gives a position of 7485. The returned data from the encoder and read through Pr **x.43** is given below:

Word number	Returned value	Data in decimal	Data in binary
1	32768	00	0000 0000
2	32768	00	0000 0000
3	32768	00	0000 0000
4	32768	00	0000 0000
5	32768	00	0000 0000
6	32927	159	1001 1111
7	32846	78	0100 1110
8	49268	116	0111 0100

All the returned values have been offset by 32768, which is the most significant bit. The last byte has an addition offset of 16384 to denote that it is the last byte.

Words 5 to 8 are the position with the least significant bit in word 5. Below are the numbers laid out in the correct order:

Word 8	Word 7	Word 6	Word 5
116	78	159	00
0111 0100	0100 1110	1001 1111	0000 0000

Shifted to turns and position (which is 12 bits then 13 bits):

0111 0100 0100	1 1101 0011 1110
(end of turns and start of the position)	
1860	7486

So the absolute position is 1860/7486 which should be compared to the displayed interpolated position of 1860/7485.

8.1.2 SSI and EndAt

Encoder Comms Resolution

Where encoder comms alone is used the encoder single turn comms resolution Pr **x.11** and the encoder turns bits Pr **x.09** must be set correctly. Although Pr **x.11** can be set to any value from 0 to 32, if the value is less than 1, the resolution is 1 bit.

Some SSI encoders include a power supply monitor alarm using the least significant bit of the position. It is possible for the drive to monitor this bit and produce an EnC6 trip if the power supply is too low see Pr **x.17**. If the encoder gives this information the comms resolution should be set up to include this bit whether or not it is being monitored by the drive.

It is possible for the drive to set up this parameter automatically from information obtained from the encoder via the EndAt interface see Pr **x.18**.

Encoder Turns

When an encoder with comms is used, Pr **x.09** must contain the number of bits in the comms message used to give the multi-turn information. For a single turn comms encoder Pr **x.09** must be set to zero. It is possible for the drive to set up this parameter automatically from information obtained from the encoder via Hiperface or EndAt interfaces during auto configuration.

Encoder Comms Baud Rate

Pr **x.14** defines the baud rate for the encoder comms when using SSI or EndAt encoders.

Pr value	Parameter string	Baud rate
0	100	100k
1	200	200k
2	300	300k
3	400	400k
4	500	500k
5	1000	1M
6	1500	1.5M
7	2000	2M

When encoder comms is used alone the time taken to obtain the comms position must be 200µs or less.

There is a delay associated with obtaining the position from an encoder using comms alone to transmit the position. The length of this delay affects the sample rate and timing

of the position used by the drive for control. If the position within one turn can be obtained in $30\mu\text{s}$ and the whole comms message including CRC (if appropriate) can be obtained in $60\mu\text{s}$ then fast sampling is used, otherwise slow sampling is used as shown in Figure 8-1. In each case the encoder position is sampled by the encoder at the start of the comms message.

Figure 8-1 Encoder data transferral via comms

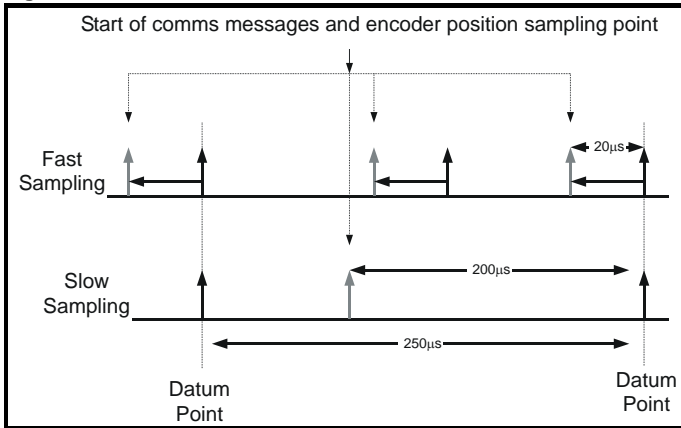

In the example the current / torque sampling rate is 4kHz, but this will change if a different switching frequency is selected. If fast sampling is used the control position used to define the drive reference frame is obtained every current/torque control sample. If slow sampling is used the control position is obtained $200\mu\text{s}$ before the datum. When fast sampling is used the delay introduced into the control system by the encoder is less, and so a higher control system bandwidth will be possible. So that the position values from the encoder can be used in a position control system compensation is provided for the delay in obtaining the position so that it appears to have been sampled at the datum. This compensation is based on the delay (i.e. $20\mu\text{s}$ or $200\mu\text{s}$) and the change of position over the previous sample (between the last two datum points).

EndAt Comms

The following equations are used by the Solutions Module to determine the time taken to obtain the position information from an EndAt encoder. These are based on $t_{\text{cal}} \leq 5\mu\text{s}$, where t_{cal} is the time from the first clock edge of the position command message from the drive to the first clock edge when the encoder responds as defined in the EndAt specification. This limit of $5\mu\text{s}$ may exclude a small number of EndAt encoders from being used by the drive as a comms only feedback device. It is also assumed that $t_{\text{D}} \leq 1.25\mu\text{s}$ where t_{D} is the data delay from the encoder as defined by the EndAt specification for 105m of cable. It should be noted that all values are rounded up to the nearest microsecond.

Command message time = $t_{\text{command}} = 10T$ or t_{cal} whichever is the longest

Where:

$$T = 1/\text{Baud Rate}, t_{\text{cal}} = 5\mu\text{s}$$

$$\begin{aligned} \text{Time for single turn position} &= t_{\text{command}} + t_{\text{D}} + (2 + \text{Single turn resolution}) \times T \\ &= t_{\text{command}} + t_{\text{D}} + (2 + \text{Pr } \mathbf{x.11}) \times T \end{aligned}$$

Where:

$$t_D = 1.25\mu\text{s}$$

Time for whole message including CRC = Time for single turn position + (Number of turns bits + 5) x T

$$= \text{Time for single turn position} + (\text{Pr } \mathbf{x.09} + 5) \times T$$

For example an encoder with 12 turns bits, 13 bit single turn resolution and a baud rate of 2M would give the following times:

Time for single turn position = 14 μs (13.75 μs rounded up)

Time for the whole message including CRC = 23 μs (22.25 μs rounded up)

SSI Comms

The whole position must be obtained from an SSI encoder before it can be used by the Solutions Module, therefore the time for the single turn position and the time for the whole message are the same. It is also assumed that $t_D \leq 1.25\mu\text{s}$, where t_D is the data delay from the encoder for 105m of cable. This value would be significantly less for shorter cable distances. It should be noted that all values are rounded up to the nearest microsecond (μs).

$$\begin{aligned} \text{Time to obtain the position} &= ((\text{No. of turns bits} + \text{Single turn resolution} + 1) \times T) + t_D \\ &= ((\text{Pr } \mathbf{x.09} + \text{Pr } \mathbf{x.11} + 1) \times T) + t_D \end{aligned}$$

For example and encoder with 12 turns bits, 13 bit single turn resolution and a baud rate of 1M would give the following time:

Time to obtain the position data = 28 μs (27.25 μs rounded up).

8.2 Electronic nameplate transfers

The electronic nameplate system is a means of storing some specific drive parameters within the EEPROM of a Stegmann or Heidenhain encoder attached to the drive. The parameters are transferred to the encoder using the Stegmann 485, or EndAt comms protocols and stored are in two categories:

- Motor object parameters
- Performance object parameters.

Loading/storing object parameters

Parameters may be transferred to or from the drive to a suitable encoder attached to the drive or one of its Solutions Modules by entering a code into Pr **x.00**, 110z0 and then resetting the drive. The z in the request defines the location of the encoder for the transfer, 0 = drive, 1 = option slot 1, 2 = option slot 2, and 3 = option slot 3.

Transfer	Data	Pr x.00 Code
Drive to encoder	Motor object parameters	110z0
Encoder to drive	Motor object parameters	110z1
Drive to encoder	Performance object block 1 parameters	110z2
Encoder to drive	Performance object block 1 parameters	110z3
Drive to encoder	Performance object block 2 parameters	110z4
Encoder to drive	Performance object block 2 parameters	110z5

Motor object parameters

The encoder can contain one motor object that holds parameters related to the motor on which the encoder is fitted and the motor load.

Pr	Description
18.11	Motor object version number**
18.12	Motor type (LSW)**
18.13	Motor type (MSW)**
18.14	Motor manufacturer**
18.15	Motor serial number (LSW)**
18.16	Motor serial number**
18.17	Motor serial number (MSW)**
1.06	Maximum speed
03.18	Motor and load inertia
03.25	Encoder phase angle
04.15	Motor thermal time constant
04.25	Low speed thermal protection mode
05.06	Rated frequency
05.07	Rated current
05.08	Rated load rpm
05.09	Rated voltage
05.10	Rated power factor
05.11	Motor poles
05.17	Stator resistance (Rs)
05.24	Transient inductance (Ls')
05.25	Stator inductance (Ls)
05.29	Motor saturation breakpoint 1
05.30	Motor saturation breakpoint 2
05.32	Motor torque per amp (Kt)
05.33	Motor volts per 1000rpm (Ke)

** The motor object includes some data that does not normally have associated parameters, but would be entered into the object by the motor manufacturer. To allow this data to be transferred to an encoder from a drive without additional equipment, Pr **18.11** to Pr **18.17** can be used to transfer this data if Pr **3.49** is set to one.

Performance object parameters

The encoder can contain up to 2 performance objects each of which contains a set of parameters that can be used to give different levels of motor performance.

Pr	Performance object 1 Description	Performance object 2 Description
3.10	Speed controller Kp gain	Speed controller Kp gain
3.11	Speed controller Ki gain	Speed controller Ki gain
3.12	Speed controller Kd gain	Speed controller Kd gain
3.17	Speed controller set-up method	Speed controller set-up method
3.19	Compliance angle	Compliance angle
3.20	Bandwidth	Bandwidth
3.21	Damping factor	Damping factor
4.05	Motoring current limit	Motoring current limit
4.06	Regen current limit	Regen current limit
4.12	Torque demand filter	Torque demand filter
4.13	Current controller Kp gain	Current controller Kp gain
4.14	Current controller Ki gain	Current controller Ki gain

It should be noted that the data within the objects in the encoder is undefined until it has been written and that the manufacturer's data is undefined until it has been written by a complete motor object write with Pr **3.49** set to one. If a value stored in the nameplate data exceeds the maximum of a parameter when the data is transferred the parameter in the drive is not updated.

The checksum for each object is Zero – sum of bytes in the object excluding the checksum itself. The number of bytes defines the number of bytes used to generate the checksum. This includes all the parameters and the number of bytes parameter, and so this value will always be 62 for the motor object and 30 for a performance object.

When either a motor or performance object is transferred to the drive all drive parameters are saved. When a performance object is loaded the speed control gain select parameter is automatically set to zero. Therefore either the speed controller gains defined in the performance object or those derived from the compliance angle, bandwidth and damping factor parameters are used.

Encoder cable length

The allowable encoder cable length is determined / specified by either:

- The encoder manufacturer
- The cable manufacturer (specified transmission delay and line attenuation rating).

Data sampling - transmission delays

The encoder begins setting the data up on the falling edge of the clock. The Unidrive SP samples the data line level on the rising edge of the clock. The maximum permissible delay between the clock falling edge at the drive and the data being correct at the drive is thus half the clock period.

The delay is made up of the transmission delays of:

- The clock signal down the line to the encoder
- The encoder data set up time
- The transmission delay of the data level returning from the encoder to the drive.

The transmission delay is a factor of the cable used. The following table gives examples of m/s transmission characteristics of three different cable types.

Cable	Transmission m/s
A	2.78×10^8
B	1.78×10^8
C	1.33×10^8

The following table give the maximum delay for each baud rate as well as the approximate maximum cable length for cables with specific metre per second transmission characteristics (neglecting data set-up delay):

Frequency (Baud rate)	Maximum delay	Approximate maximum cable lengths		
		A	B	C
100 kHz	5 μ s	694 m	445 m	331 m
200 kHz	2.5 μ s	347 m	222 m	165 m
300 kHz	1.66 μ s	231 m	148 m	110 m
400 kHz	1.25 μ s	173 m	111 m	82 m
500 kHz	1 μ s	138 m	89 m	66 m
1 MHz	500 ns	69 m	44 m	33 m
1.5 MHz	333 ns	46 m	29 m	22 m
2 MHz	250 ns	34 m	22 m	16 m

Clock output - line attenuation

Assuming a model for a basic performance screened cable of 60m Ω and 250pF per/m and the minimum generator and receiver specifications (for one to one installations using RS485), the approximate maximum frequency (baud rate) per cable length is given below:

Length	Time constant	Maximum frequency (Baud rate)
10	2.97×10^{-9}	150 MHz
50	7.14×10^{-8}	6 MHz
100	2.73×10^{-7}	1.5 MHz
150	5.87×10^{-7}	651 kHz
200	1.00×10^{-6}	363 kHz
250	1.50×10^{-6}	230 kHz
300	2.08×10^{-6}	158 kHz
350	2.72×10^{-6}	115 kHz
400	3.43×10^{-6}	87 kHz
450	4.19×10^{-6}	68 kHz
500	5.00×10^{-6}	54 kHz

A standard cable would allow improved performance.

9 Parameters

9.1 Introduction

The parameters listed in this chapter are used for programming and monitoring the SM-Universal Encoder Plus.

NOTE The same parameter structure is available in menu 15, 16 and 17 referring to slots 1, 2 and 3.



Before attempting to adjust any parameters, refer to Chapter 2 *Safety Information* on page 6.

Table 9.1 Key to parameter coding

Coding	Attribute
RW	Read/write: can be written by the user
RO	Read only: can only be read by the user
Bit	1 bit parameter
Bi	Bipolar parameter
Uni	Unipolar parameter
Txt	Text: the parameter uses text strings instead of numbers.
FI	Filtered: some parameters which can have rapidly changing values are filtered when displayed on the drive keypad for easy viewing.
DE	Destination: indicates that this parameter can be a destination parameter.
RA	Rating dependant: this parameter is likely to have different values and ranges with drives of different voltage and current ratings. This parameters is not transferred by smart cards when the rating of the destination drive is different from the source drive.
NC	Not cloned: not transferred to or from smart cards during cloning.
PT	Protected: cannot be used as a destination.
US	User save: saved in drive EEPROM when the user initiates a parameter save.
PS	Power-down save: automatically saved in drive EEPROM at power-down.

9.2 Single line descriptions

Parameter		Range(↕)		Default(⇔)			Type					
		OL	CL	OL	VT	SV						
x.01	Solutions Module ID	0 to 599					RO	Uni			PT	US
x.02	Solutions Module software version	0.0 to 99.99					RO	Uni		NC	PT	
x.03	Speed	±40,000.0 rpm					RO	Bi	FI	NC	PT	
x.04	Revolution counter	0 to 65,535 revolutions					RO	Uni	FI	NC	PT	
x.05	Position	0 to 65,535 (1/2 ¹⁶ ths of a revolution)					RO	Uni	FI	NC	PT	
x.06	Fine position	0 to 65,535 (1/2 ³² nds of a revolution)					RO	Uni	FI	NC	PT	
x.07	Marker position reset disable	OFF (0) or On (1)		OFF (0)			RW	Bit				US
x.08	Marker flag	OFF (0) or On (1)		OFF (0)			RW	Bit		NC		
x.09	Encoder turns/ linear encoder comms to sine wave ratio	0 to 16 bits		16			RW	Uni				US
x.10	Equivalent lines per revolution	0 to 50,000		4096			RW	Uni				US
x.11	Single turn comms bits/ linear encoder comms bits	0 to 32 bits		0			RW	Uni				US
x.12	Motor thermistor check <i>enable</i>	OFF (0) or On (1)		OFF (0)			RW	Bit				US
x.13	Encoder supply voltage	5V (0) 8V (1) 15V (2)		5V (0)			RW	Uni				US
x.14	Encoder comms baud rate	100 (0), 200 (1), 300 (2), 400 (3), 500 (4), 1,000 (5), 1,500 (6), 2,000 (7)		300 (2)			RW	Txt				US
x.15	Encoder type	Ab (0), Fd (1), Fr (2), Ab.SErvo (3), Fd.SErvo (4), Fr.SErvo (5), SC (6), SC.HiPEr (7), EndAt (8), SC.EndAt (9), SSI (10), SC.SSI (11), SC.SErvo(12)		Ab (0)			RW	Uni				US
x.16	Rotary encoder select/ comms only encoder mode/ terminations	0 to 2		1			RW	Uni				US
x.17	Error detection level	0 to 7		1			RW	Uni				US
x.18	Auto configuration/ SSI binary format select	OFF (0) or On (1)		OFF (0)			RW	Bit				US
x.19	Feedback filter		0 to 5 (0 to 16 ms)	0			RW	Uni				US
x.20	Maximum feedback reference	0.0 to 40,000.0 rpm		1500.0			RW	Uni				US
x.21	Feedback reference/ motor thermistor resistance	±100.0%					RO	Bi		NC	PT	
x.22	Feedback reference scaling	0.000 to 4.000		1.000			RW	Uni				US
x.23	Feedback reference destination	Pr 0.00 to Pr 21.51		Pr 0.00			RW	Uni	DE		PT	US
x.24	Encoder simulation source	Pr 0.00 to Pr 21.51		Pr 0.00			RW	Uni			PT	US
x.25	Encoder simulation ratio numerator	0.0000 to 3.0000		0.2500			RW	Uni				US
x.26	Encoder simulation ratio denominator	0.0000 to 3.0000		1.0000			RW	Uni				US

Parameter		Range(⇅)		Default(⇔)			Type				
		OL	CL	OL	VT	SV					
x.27	Encoder simulation resolution select	OFF (0) or On (1)		OFF (0)			RW	Bit		NC	
x.28	Encoder simulation mode	Ab (0), Fd (1), SSI.Gray (2), SSI.Bin (3), Ab.L (4), Fd.L (5), H-driv (6), H-int (7)		Ab (0)			RW	Txt			US
x.29	Non-marker reset revolution counter	0 to 65,535 revolutions					RO	Uni		NC	PT
x.30	Non-marker reset position	0 to 65,535 (1/2 ¹⁶ ths of a revolution)					RO	Uni		NC	PT
x.31	Non-marker reset fine position	0 to 65,535 (1/2 ³² nds of a revolution)					RO	Uni		NC	PT
x.32	Marker revolution counter	0 to 65,535 revolutions					RO	Uni		NC	PT
x.33	Marker position	0 to 65,535 (1/2 ¹⁶ ths of a revolution)					RO	Uni		NC	PT
x.34	Marker fine position	0 to 65,535 (1/2 ³² nds of a revolution)					RO	Uni		NC	PT
x.35	Freeze revolution counter	0 to 65,535 revolutions					RO	Uni		NC	PT
x.36	Freeze position	0 to 65,535 (1/2 ¹⁶ ths of a revolution)					RO	Uni		NC	PT
x.37	Freeze fine position	0 to 65,535 (1/2 ³² nds of a revolution)					RO	Uni		NC	PT
x.38	Freeze input mode/ Marker output select	0 to 7		1			RW	Uni			US
x.39	Freeze flag	OFF (0) or On (1)		OFF (0)			RW	Bit		NC	
x.40	Pass freeze to drive and other slots	OFF (0) or On (1)		OFF (0)			RW	Bit		NC	US
x.41	Freeze invert	OFF (0) or On (1)		OFF (0)			RW	Bit			US
x.42	Encoder comms transmit register/ Sin signal value/ commutation signal level	0 to 65,535		0			RW	Uni		NC	
x.43	Encoder comms receive register/ Cos signal value	0 to 65,535		0			RW	Uni		NC	
x.44	Disable encoder position check	OFF (0) or On (1)		OFF (0)			RW	Bit		NC	
x.45	Position feedback initialised	OFF (0) or On (1)					RO	Bit		NC	PT
x.46	Lines per revolution divider	1 to 1024		1			RW	Uni			US
x.47	SSI output turns	0 to 16		16			RW	Uni			US
x.48	SSI output comms resolution	0 to 32 bits		0			RW	Uni			US
x.49	Lock position feedback	OFF (0) or On (1)		OFF (0)			RW	Bit			
x.50	Solutions Module error status	0 to 255					RO	Uni		NC	PT
x.51	Solutions Module software sub-version	0 to 99					RO	Uni		NC	PT

RW	Read / Write	RO	Read only	Uni	Unipolar	Bi	Bi-polar
Bit	Bit parameter	Txt	Text string	FI	Filtered	DE	Destination
NC	Not cloned	RA	Rating dependent	PT	Protected	US	User save
PS	Power down save						

Figure 9-1 SM-Universal Encoder Plus logic diagram

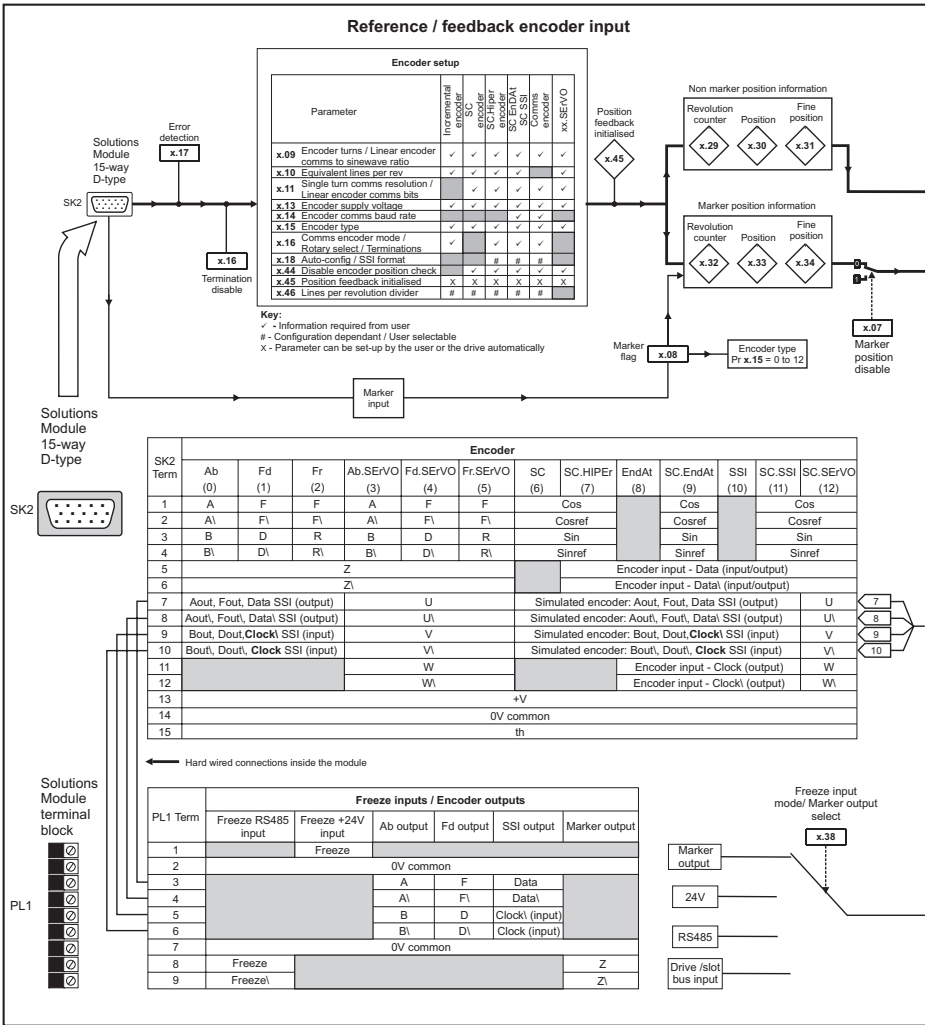

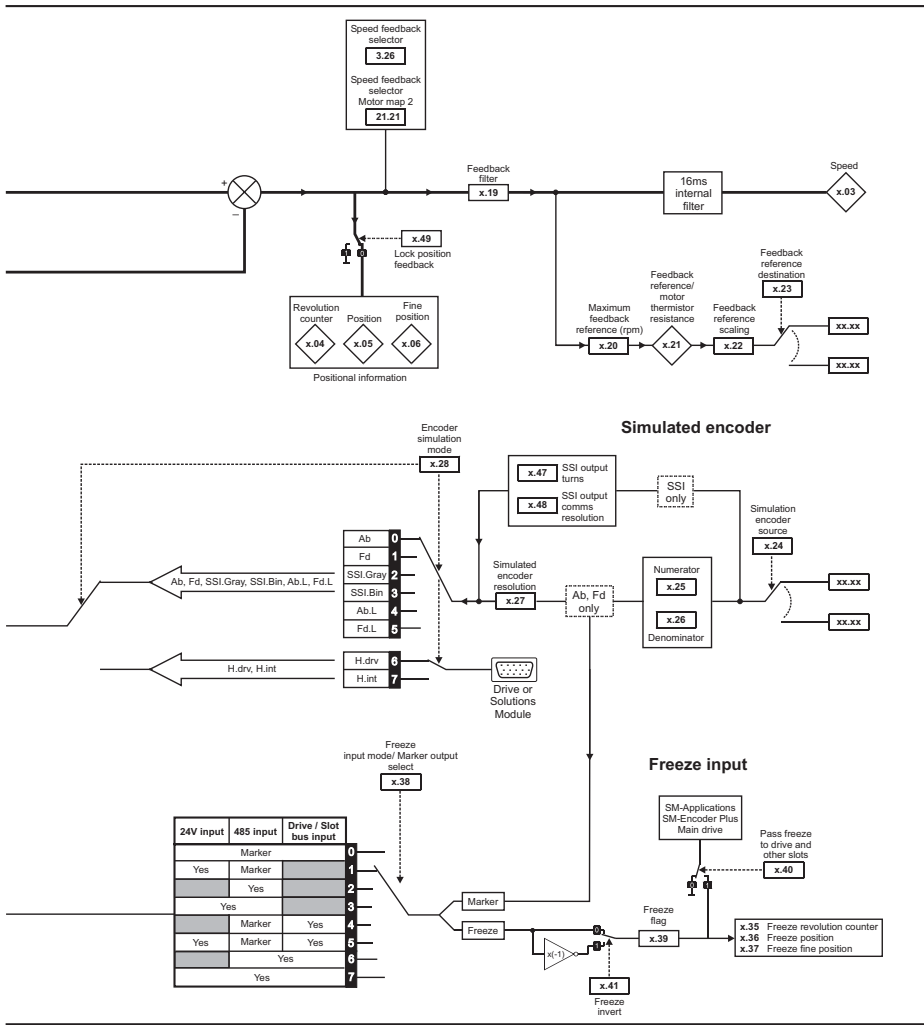

9.3 Parameter descriptions

x.01		Option ID code							
RO	Uni						PT	US	
↕	0 to 599				⇒				
Update rate: Write on power-up									

The menu for the relevant slot appears for the new Solutions Module category with the default parameter values for the new category. When no Solutions Module is fitted in the relevant slot this parameter is zero. When a Solutions Module is fitted this parameter displays the identification code as shown below.

Code	Solutions Module	Category	Dumb module
0	No Solutions Module fitted		
101	SM-Resolver	Feedback	✓
102	SM-Universal Encoder Plus		
104	SM-Encoder Plus		✓
201	SM-I/O Plus	Automation	✓
203	SM-I/O Timer		
204	SM-PELV		
206	SM-I/O 120V		
207	SM-I/O Lite		
301	SM-Applications		
302	SM-Application Lite		
303	SM-EZMotion		
403	SM-Profibus DP	Fieldbus	
404	SM-Interbus		
406	SM-CAN		
407	SM-DeviceNet		
408	SM-CANopen		
409	SM-SERCOS		
410	SM-Ethernet		
501	SM-SLM	SLM	

The new parameters values are not stored in EEPROM until the user performs a parameter save. When parameters are saved by the user in the drive EEPROM the option code of the currently fitted Solutions Module is saved in EEPROM. If the drive is subsequently powered-up with a different Solutions Module fitted, or no Solutions Module fitted where one was previously fitted, the drive gives a Slot.dF or SLot.nf trip.

x.02		Option software version							
RO	Uni					NC	PT		
↕	00.00 to 99.99				⇒				
Update rate: Write on power-up									

NOTE

When operating with an Issue 3 SM-Universal Encoder Plus, the software must be of version **03.xx.xx**. When operating with an Issue 4 SM-Universal Encoder Plus, the software must be of version **04.xx.xx**.

Failure to comply with the above can result in Solutions Module failure.

x.03		Speed							
RO	Bi	FI				NC	PT		
↕	±40,000.0 rpm				⇒				
Update rate: 4ms write									

Provided the set-up parameters for the position feedback are correct this parameter shows the speed in rpm, this parameter is filtered to give a readable indication of speed.

x.04		Revolution counter							
RO	Uni	FI				NC	PT		
↕	0 to 65535 revolutions				⇒				
Update rate: 4ms write									

x.05		Position							
RO	Uni	FI				NC	PT		
↕	0 to 65535 (1/2 ¹⁶ ths of a revolution)				⇒				
Update rate: 4ms write									

Standard source for simulated encoder output with feedback position being updated every 250µs for the simulated encoder output. Pr x.05 display value is updated every 4ms.

x.06		Fine position							
RO	Uni	FI				NC	PT		
↕	0 to 65535 (1/2 ³² nds of a revolution)				⇒				
Update rate: 4ms write									

These parameters give the position with a resolution of 1/2³²ths of a revolution as a 48 bit number as shown below.

47	32	31	16	15	0
Revolutions		Position		Fine position	

Provided the set-up parameters are correct, the position is always converted to units of 1/2³²ths of a revolution, but some parts of the value may not be relevant depending on the resolution of the feedback device.

Example:

A 1024 line digital encoder produces 4096 counts per revolution, and so the position is represented by the bits in the shaded area only.

47	32	31	20	19	16	15	0
Revolutions		Position				Fine position	

When the feedback device rotates by more than one revolution, the revolutions in Pr x.04 increment or decrement in the form of a sixteen bit roll-over counter. If an absolute position feedback is used the position is initialised at power-up with the

absolute position.

If a linear encoder is used the turns information is used to represent the movement by the number of poles defined by Pr 5.11. Therefore if the number of poles is set to two, one revolution is the movement by one pole pitch.

NOTE

It may be required that Pr x.04, Pr x.05 and Pr x.06 are reset to zero this can be carried out by changing the encoder type Pr x.15 with all counters being reset.

x.07		Marker position reset disable								
RW	Bit							US		
↕		OFF (0) or On (1)				⇒	OFF (0)			
Update rate: Background read										

x.08		Marker flag								
RW	Bit					NC				
↕		OFF (0) or On (1)				⇒	OFF (0)			
Update rate: 4ms write										

An incremental digital encoder may have a marker channel and when this channel becomes active (rising edge in the forward direction and falling edge in reverse) it may be used to reset the encoder position and set the marker flag (Pr x.07 = 0), or just to set the marker flag (Pr x.07 = 1). When the position is reset by the marker, Pr x.05 and Pr x.06 are reset to zero.

The marker flag is set each time the marker input becomes active, but it is not reset by the Solutions Module, and so this must be done by the user. The marker function only operates when Ab, Fd, Fr, Ab.SErvo, Fd.SErvo, Fr.SErvo, SC.SErvo type encoders are selected with Pr x.15.

x.09		Encoder turns/ linear encoder comms to sine wave ratio								
RW	Uni					NC		US		
↕		0 to 255				⇒	16			
Update rate: Background read										

This parameter has a different function depending on the type of encoder selected with Pr x.15 and Pr x.16.

Ab, Fd, Fr, Ab.SErvo, Fd.SErvo, Fr.SErvo, SC, SC.SErvo

It is sometimes desirable to mask off the most significant bits of the revolution counter with these types of encoders. This does not have to be done for the drive to function correctly. If Pr x.09 is zero the revolution counter (Pr x.04) is held at zero. If Pr x.09 has any other value it defines the maximum number of the revolution counter before it is reset to zero.

Example, if Pr x.09=5, then Pr x.04 counts up to 31 before being reset. If Pr x.09 is greater than 16 the number of turns bits is 16 and Pr x.04 counts up to 65535 before being reset.

SC.HiPEr, SC.EndAt, SC.SSI and Pr x.16 = 1 or 2 (Rotary encoder)

Pr x.09 must contain the number of bits in the comms message used to give the multi-turn information. For a single turn comms encoder, Pr x.09 must be set to zero. As well as setting the number of comms turns bits this parameter also sets up a mask on the turns displayed in Pr x.04 as described above.

With SC.HiPEr or SC.EndAt encoders it is possible for this parameter to be obtained automatically from the encoder (see Pr x.18). If Pr x.09 is greater than 16 the number of turns bits is 16.

SC.HiPEr, SC.EndAt, SC.SSI and x.16 = 0 (Linear encoder)

When a linear encoder is selected no mask is placed on the turns information displayed in Pr x.09, and so this parameter always displays the turns information as a full 16 bit value with a maximum of 65535. Linear SINCOS encoders with comms are normally specified with a length for each sine wave period and the length for the least significant bit of the position in the comms message. Pr x.09 should be set up with the ratio between these two lengths so that the Solutions Module can determine the encoder position during initialisation.

The Linear encoder comms to sine wave ratio is defined as follows:

$$\text{Linear encoder comms to sine wave ratio} = \frac{\text{Length for sine wave period}}{\text{Length of the LS bit of the position in the comms}}$$

With SC.HiPEr or SC.EndAt encoders it is possible for this parameter to be obtained automatically from the encoder (see Pr x.18).

EndAt, SSI

Pr x.09 must contain the number of bits in the comms message used to give the multi-turn information. For a single turn comms encoder, Pr x.09 must be set to zero. As well as setting the number of comms turns bits this parameter also sets up a mask on the turns displayed in Pr x.04 as described above. It is possible for this parameter to be obtained automatically from the encoder (see Pr x.18). If Pr x.09 is greater than 16 the number of turns bit is 16.

NOTE

It should be noted that if the Pr x.19 the Feedback Filter is used where, the speed feedback is provided by either an EndAt or SSI encoder connected directly to the module, it is necessary for the encoder to provide at least 6 bits of turns information. This is not a problem when the position is defined by the absolute position from the encoder at initialisation and then accumulated delta positions (Pr x.16 = 0), however, if the absolute position is taken directly from the encoder (Pr x.16 > 0) the encoder must provide at least 6 bits of turns information.

If the Feedback filter Pr x.19 is not used turns information from the encoder is not required.

x.10		Equivalent lines per revolution							
RW	Uni								US
↕		0 to 50000			⇒	4096			
Update rate: Background read									

When Ab, Fd, Fr, Ab.SErvo, Fd.SErvo, Fr.SErvo or SINCOS signals are used the equivalent number of encoder lines per revolution must be set-up correctly in Pr x.10 to give the correct speed and position feedback. This is particularly important if the encoder is selected for speed feedback with Pr 3.26. The equivalent number of encoder lines per revolution (ELPR) is defined as follows.

Position feedback device	ELPR
Ab, Ab.SErvo	number of lines per revolution
Fd, Fr, Fd.SErvo, Fr.SErvo	number of lines per revolution / 2
SC.HiPEr, SC.EndAt, SC, SC.SErvo	number of sine waves per revolution

For any type of linear encoder one revolution is the motor pole pitch multiplied by the number of poles set up in Pr 5.11.

Ab, Fd, Fr, Ab.SErvo, Fd.SErvo and Fr.SErvo

The incremental signal frequency should not exceed 600kHz. SC.HiPEr, SC.EndAt, SC.SErvo, SC and SC.SSI

NOTE The absolute maximum sine wave signal frequency is 166kHz (version 3.x.x) 250kHz (version 4.x.x).

The encoder port is designed to give 10 bits of interpolation resolution at 115kHz. The resolution is reduced at frequencies higher than 115kHz and at peak to peak differential voltages less than 1 volt. The total resolution in bits per revolution is the ELPR plus the number of bits of interpolated information.

The table below shows the number of bits of interpolated information at different frequencies and with different voltage levels at the drive encoder port.

Volt/Freq	1,000	5,000	50,000	100,000	150,000	200,000	250,000
1.2	11	11	11	10	10	9	9
1.0	11	11	10	10	9	9	8
0.8	10	10	10	10	9	8	8
0.6	10	10	10	9	9	8	7
0.4	9	9	9	9	8	7	7

NOTE 200kHz and 250kHz are not available with hardware versions less than 4.x.x

If the position feedback device is a rotary SINCOS encoder with comms the position supplied via comms gives a number of counts per revolution that is a power of two and the resolution is defined by the single turns comms bit (Pr x.11).

When Pr x.11 is adjusted an "Initialisation failed - 7" trip is produced, because the encoder requires re-initialisation.

EndAt, SSI

Where encoder comms alone is used as position feedback, the equivalent lines per revolution (Pr x.10) is not used in setting up the encoder interface. It is possible for the drive to set up this parameter automatically from information obtained from an EndAt encoder (see Pr x.18).

The equivalent lines per revolution in Pr x.10 can be divided where required using Pr x.46 line per revolution divider.

Example 128.123 lines per revolution would be set as 128123 in Pr x.10 and 100 in Pr x.46 giving 128123 / 1000 = 128.123

x.11		Single turns comms bits/ linear encoder comms bits						
RW	Uni							US
⇕	0 to 32 bits			⇒	0			
Update rate: Background read								

Where encoder comms is used for initial setting of absolute position (SC.HiPEr or SC.EndAt), the comms resolution in bits must be set correctly, either by the user or the

drive (see Pr **x.18**), in Pr **x.11**. The comms resolution may be higher than the resolution of the sine waves per revolution.

Ab, Fd, Fr, Ab.SERvo, Fd.SERvo, Fr.SERvo, SC, SC.SERvo

Pr **x.11** has no effect.

SC.HiPEr, SC.EndAt, SC.SSI and x.16 = 1 or 2 (Rotary encoder)

Pr **x.11** must be set to the number of comms bits used to represent one revolution of the encoder. The single turn comms resolution may be higher than the resolution of the sine waves per revolution.

SC.HiPEr, SC.EndAt, SC.SSI and x.16 = 0 (Linear encoder)

Pr **x.11** must be set up to the total number of bits representing the whole encoder position in the comms message.

This parameter is not used with linear SC.HiPEr encoders as the number of bits used to represent the whole position is always 32.

EndAt, SSI

Pr **x.11** must be set to the number of bits used to represent one revolution of the encoder.

Although Pr **x.11** can be set to any value from 0 to 32, if the value is less than 1, the resolution is 1 bit. Some SSI encoders (SC.SSI or SSI) include a power supply monitor alarm using the least significant bit of the position. It is possible for the drive to monitor this bit and produce a trip 6 if the power supply is too low (see Pr **x.17**). If the encoder gives this information the comms resolution should be set up to include this bit whether it is being monitored by the Solutions Module or not.

It is possible for the drive to set up this parameter automatically from encoder information via Hiperface or EndAt interfaces (see Pr **x.18**).

x.12		Motor thermistor check enable								
RW	Bit							US		
↕		OFF (0) or On (1)				⇒	OFF (0)			
Update rate: Background read										

The motor thermistor if connected to the Solutions Module for temperature monitoring is enabled through this parameter.

Refer to section 6.7 *Thermistor input* on page 55 for full details.

x.13		Encoder supply voltage								
RW	Uni							US		
↕		0 to 2				⇒	0			
Update rate: Background read										

The encoder supply voltage present on the SM-Universal Encoder is defined by this parameter as 0(5V), 1(8V), or 2(15V).

x.14		Encoder comms baud rate								
RW	Txt							US		
↕		0 to 7				⇒	2			
Update rate: Background read										

This parameter defines the baud rate for the encoder comms when using encoders with either SSI or EndAt interfaces. A fixed baud rate of 9600 is used with Hiperface

encoders and this parameter has no effect. Any baud rate can be used when encoder comms is used with a SINCOS encoder to obtain the absolute position during initialisation.

Pr value	Pr string	Baud rate
0	100	100k
1	200	200k
2	300	300k
3	400	400k
4	500	500k
5	1000	1M
6	1500	1.5M
7	2000	2M

When the encoder comms is used and the position within one turn can be obtained in 30µs and the rest of the message including CRC within a further 30µs (60µs total) the encoder position for control is taken during each level 1 interrupt (fast sampling).

If either of these conditions is not met the position is taken every 250µs. The position feedback used for speed control is taken every 250µs irrespective of the encoder message time. The comms message must not be longer than 200µs otherwise position feedback errors will occur. Compensation based on the speed over the previous 250µs is applied to correct the position so that it appears to have been taken at the encoder datum used by all other encoder types.

If fast sampling is used the control position used to define the drive reference frame is obtained every current/torque control sample (switching frequency selected dependant). If slow sampling is used the control position is obtained every 200µs.

When fast sampling is used the delay introduced into the control system by the encoder is less, and so a higher control system bandwidth will be possible (position values from the encoder could be used in a position control system).

NOTE

Also refer to Chapter 8 *Advanced Operation* on page 58, for further detailed information on operation with encoder serial comms.

x.15		Encoder type					
RW	Uni					US	
↕	0 to 12			⇒	0		
Update rate: Background read							

The following encoders can be connected to the SM-Universal Encoder Plus.

- 0, Ab: Quadrature incremental encoder, with or without marker pulse**
- 1, Fd: Incremental encoder with frequency and direction outputs, with or without marker pulse**
- 2, Fr: Incremental encoder with forward and reverse outputs, with or without marker pulse**
- 3, Ab.SErvo: Quadrature incremental encoder with commutation outputs, with or without marker pulse**
- 4, Fd.SErvo: Incremental encoder with frequency, direction and commutation outputs, with or without marker pulse**
- 5, Fr.SErvo: Incremental encoder with forward, reverse and commutation outputs, with or without marker pulse**

U, V, W commutation signals are required with an incremental type encoder when used with a servo motor.

The UVW commutation signals are used to define the motor position during the first 120° electrical rotation after the drive is powered-up or the encoder is initialised.

6, SC: SinCos encoder with no serial communications

This type of encoder gives incremental position and can only be used for control in Closed-loop vector mode.

7, SC.HiPER: Absolute SinCos encoder using Stegmann 485 comms protocol (HiPerFace).

This type of encoder gives absolute position and can be used for motor control in closed-loop vector or servo modes. The Solutions Module can check the position from the sine and cosine waveforms against the internal encoder position using serial communications and if an error occurs the Solutions Module trips the drive. Additional communications with the encoder is possible.

8, EndAt: Absolute EndAt only encoder

This type of encoder gives absolute position and can be used for motor control in closed-loop vector or servo modes. Additional communications with the encoder is not possible.

9, SC.EndAt: Absolute SinCos encoder using EndAt comms protocol

This type of encoder gives absolute position and can be used for motor control in closed-loop vector or servo modes. The Solutions Module can check the position from the sine and cosine waveforms against the internal encoder position using serial communications and if an error occurs the drive trips. Additional communications with the encoder is possible.

10, SSI: Absolute SSI only encoder

This type of encoder gives absolute position and can be used for motor control in closed-loop vector or servo modes. Additional communications with the encoder is not possible. SSI encoders use either gray code or binary format which can be selected with Pr **x.18**. Most SSI encoders use 13 bit single turn position information, and so Pr **x.11** should normally be set to 13. If the single turn resolution of the encoder is lower then the least significant bits of the data are always zero. Some SSI encoders use the least significant bit to show the status of the encoder power supply. In this case the single turn position resolution should be set to include this bit, but the Solutions Module should be set up to monitor it via Pr **x.17**. Some SSI encoders use a right shifted format where the unused single turn position bits are removed instead of being set to zero. For these encoders the single turn position resolution should be set to the number of bits used for the single turn position.

NOTE

If an Absolute SSI only encoder is used with a data transfer rate of >30µs timing problems may occur, resulting in speed feedback instability.

11, SC.SSI: SinCos encoder using SSI comms protocol

This type of encoder gives absolute position and can be used for motor control in Closed-loop vector or Servo modes. The drive can check the position from the sine and cosine waveforms against the internal encoder position using serial communications and if an error occurs the drive trips.

12, SC.Servo: SinCos encoder with UVW communication outputs

The type of encoder gives absolute position and can be used for motor control in closed-loop vector or servo modes. U, V, W commutation outputs are required with a SinCos type encoder when used with a servo motor. The U, V, W commutation outputs are used to define the motor position during the first 120° electrical rotation after the drive is powered-up or the encoder is initialised.

The following should be noted:

It should be noted that all SINCOS encoders and encoders using communications must be initialised before their position data can be used. The encoder is automatically initialised at power-up or when the initialisation parameter (Pr 3.47) is set to 1.

In addition to using all the above encoders types as position feedback from a motor, they may be used as a position reference for the drive position controller or a position controller application in an Solutions Module etc. When a comms only encoder interface is used, it is possible to instantly change the position by a large number of turns. This can cause a position error in the drive if the change over a 250µs period appears to produce a speed of greater than 40,000rpm. Therefore if the EndAt or SSI interface is used to provide a reference the change over each 250µs sample must not exceed 0.16 turns. If the position is incorrect because the change is too large this can be corrected by re-initialising the encoder interface, Pr 3.47.

If an SSI encoder is used, but is not powered from the drive, and the encoder is powered up after the drive it is possible that the first change of position detected could be big enough to cause the problem described above. This can be avoided if the encoder interface is initialised via Pr 3.47 after the encoder has powered up. If the encoder includes a bit that indicates the status of the power supply the power supply monitor should be enabled, Pr 3.40.

Trips can be enabled/disabled using Pr 3.40 as follows.

Bit	Function
0	Wire break detect
1	Phase error detect
2	SSI power supply bit monitor

This will ensure that the drive remains tripped until the encoder is powered up and the action of resetting the trip will re-initialise the encoder interface.

x.16		Encoder termination/rotary encoder select/comms only encoder mode							
RW	Txt							US	
↕	0 to 2			⇔	1				
Update rate: Background read									

Encoder termination select**Ab, Fd, Fr, Ab.SErvo, Fd.SErvo, Fr.SErvo.**

The terminations may be enabled/disabled by this parameter as follows:

Encoder input	Pr x.16=0	Pr x.16=1	Pr x.16=2
A-A\	Disabled	Enabled	Enabled
B-B\	Disabled	Enabled	Enabled
Z-Z\	Disabled	Disabled	Enabled
U-U\, V-V\, W-W\	Enabled	Enabled	Enabled

SC- Not used

Pr x.16 has no effect

SC.SErvo

U-U\, V-V\, W-W\ and Sin and Cos signals are terminated and cannot be disabled.

SC.HiPEr, SC.EndAt, SC.SSI - Rotary encoder select

If Pr x.16 is set to 1 or 2 the encoder is a rotary encoder and the following applies

1. Pr **x.09** defines the number of turns bits in the comms message from the encoder and a mask is applied to Pr **x.04** to remove turns bits in excess of those provided in the encoder comms position.
2. Pr **x.11** defines the number of comms bits used to define a single turn.
If Pr **x.16** is set to 0 the encoder is a linear encoder and the following apply:
 1. Pr **x.09** defines the ratio between the length of a sine wave period and the length of the least significant comms bit.
 2. No mask is applied to the turns displayed in Pr **x.04**.
 3. Pr **x.11** defines the number of comms bits used to give the whole position value.
If the position feedback device is SC.HiPEr or SC.EndAt it is possible for the drive to set up this parameter automatically from information obtained from the encoder (see Pr **x.18**).

EndAt, SSI - Comms only encoder mode

If this parameter is set to 1 or 2 the drive always takes the complete absolute position for these comms only type encoders. The turns (Pr **x.04**), position (Pr **x.05**) and fine position (Pr **x.06**) will be an exact representation of the position from the encoder.

If the encoder does not provide 16bits of turns information, the internal representation of the turns used by the position controller in Menu 13 and functions within the SM-Applications Module such as the Advanced Position Controller, rolls over at the maximum position value from the encoder. This jump in position is likely to cause unwanted effects.

EndAt

The EndAt format includes a CRC that is used by the drive to detect corrupted data, and so if the position data has been corrupted the drive uses the previous correct data until new uncorrupted data is received.

If this parameter is set to 0 the drive only takes the absolute position directly from the encoder during initialisation. The change of position over each sample is then used to determine the current position. This method always gives 16 bits of turns information that can be used without jumps in position by the position controller in Menu13 and SM-applications modules etc. This method will only operate correctly if the change of position over any 250µs period is less than 0.5 of a turn, or else the turns information will be incorrect. The turns can then only be corrected by re-initialising the encoder. This problem should not occur with EndAt encoders because three consecutive corrupted messages at the slowest sample rate (i.e. 250µs) would be required even at the maximum speed of 40,000rpm before the change of position would be the required 0.5 turns to give possible corruption of the turns information. If three consecutive messages with CRC errors occur this will cause the drive to produce an EnC5 trip. The drive can only be re-enabled after the trip is reset which will re-initialise the encoder and correct the absolute turns

SSI

As the SSI format does not include any error checking and it is not possible for the drive to detect if the position data has been corrupted. The benefit of using the absolute position directly from an SSI encoder is that even if the encoder communications are disturbed by noise and position errors occur, the position will always recover the correct position after the disturbance has ceased.

Under normal operating conditions and at a maximum speed of 40,000rpm the maximum change of position is less than 0.5 turns, however, if noise corrupts the data from an SSI encoder it is possible to have apparent large change of position, and this can result in the turns information becoming and remaining corrupted until the encoder is re-initialised.

If an SSI encoder is used, but is not powered from the drive, and the encoder is powered up after the drive, it is possible that the first change of position detected could be large enough to cause the problem described above. This can be avoided if the encoder interface is initialised via Pr 3.47 after the encoder has powered up. If the encoder includes a bit that indicates the status of the power supply the power supply monitor should be enabled (see Pr x.17). This will ensure that the drive remains tripped until the encoder is powered up and the action of resetting the trip will reinitialise the encoder interface.

x.17		Error detection level						
RW	Uni						US	
↕	0 to 7			⇒	0			
Update rate: Background read								

Trips can be enabled/disabled using Pr x.17 as follows:

Bit	Function
0	Wire break detect
1	Phase error detect
2	SSI power supply monitor

The binary sum defines the level of error detection as below:

Bit 2	Bit 1	Bit 0	Error detection level	Pr x.17
0	0	0	Error detection disabled	0
0	0	1	Wire break detect	1
0	1	0	Phase error detect	2
0	1	1	Wire break + phase error detect	3
1	0	0	SSI power supply bit monitor	4
1	0	1	Wire break + SSI power supply bit monitor	5
1	1	0	Phase error detect + SSI power supply bit monitor	6
1	1	1	Wire break detect + phase error detect + SSI power supply bit monitor	7

NOTE If SSI power supply bit monitor feature is enabled ensure that this has been configured for an encoder setup Pr x.09, Pr x.11.

NOTE In order for the phase error detection to function correctly the LPR of the SC.HiPEr, SC.EndAt and SC.SSI encoder must be greater than 9 x number of motor poles (e.g 54 for a 6 pole servo motor)

x.18		Auto configuration enable / SSI binary format select						
RW	Bit						US	
↕	OFF (0) or On (1)			⇒	OFF (0)			
Update rate: Background read								

SC.HiPEr, SC.EndAt, EndAt

When an SC.HiPEr, SC.EndAt or EndAt encoder is being used, the Solutions Module will interrogate the encoder on power-up. If Pr x.18 is set to one and the encoder type is recognised based on the information provided by the encoder, the Solutions Module will set-up.

1. The encoder turns / linear encoder comms to sine wave ratio (Pr **x.09**)
2. The equivalent lines per revolution (Pr **x.10**)
3. The encoder comms resolution / linear encoder comms bits (Pr **x.11**)

For SC.HiPEr or SC.EndAt encoders the rotary encoder select (Pr **x.16**) is also set up. If the encoder is not recognised, there is a comms error or the resulting parameter values are out of range the Solutions Module initiates a trip 7 or 12 to 16 trip to prompt the user to enter the information. The Solutions Module can auto-configure with any of the following devices.

Rotary EndAt encoders

The encoder turns, comms resolution and equivalent lines per rev are set up directly using the data read from the encoder.

Linear EndAt encoders

The comms resolution is set to the number of bits required for the whole position within the position data messages from the encoder. The linear encoder comms to sine wave ratio is calculated from the sine wave period and LS comms bit length. The encoder does not give the equivalent lines per rev directly, but gives the length of a sinewave period in mm. Therefore the Solutions Module uses the pole pitch (Pr **5.36**) and the number of motor poles (Pr **5.11**) for the motor to calculate the equivalent lines per revolution.

$$\text{ELPR} = \text{Pole pitch} \times \text{Number of motor pole pairs} / \text{Length of a sinewave}$$

Normally the Number of motor poles will be set to 2, and so:

$$\text{ELPR} = \text{Pole pitch} / \text{Length of a sinewave}$$

It should be noted that the equivalent lines per revolution parameter is only updated when auto-configuration occurs, i.e. when the encoder is initialised, and that it uses the pole pitch for the active motor. The value for Pole pitch x Number of motor pole pairs is limited to 655.35mm by the drive. If the pole pitch is left at its default value of zero which would give ELPR = 0, or the result of the calculation is over 50000, the drive will initiate an Enc15 trip.

NOTE The ELPR divider (Pr **x.46**) is returned to 1 if auto-configuration completes correctly.

Hiperface encoders

The Solutions Module can recognise any of the following devices: SCS 60/70, SCM 60/70, SRS 50/60, SRM 50/60, SHS 170, LINCODER, SCS-KIT 101, SKS36, SKM36, SEK52 and SEK53. If the Solutions Module cannot recognise the encoder type it will initiate 12 trip.

NOTE The ELPR divider (Pr **x.46**) is returned to 1 if auto-configuration completes correctly.

SC.SSI, SSI

SSI encoders normally use gray code data format. However, some encoders use binary format that may be selected by setting this parameter to one.

x.19		Feedback filter							
RW	Uni								US
↕	0 (0), 1 (1), 2 (2), 4 (3), 8 (4), 16 (5) ms				⇒				0 (0)
Update rate: Background read									

0 = 0ms, 1 = 1ms, 2 = 2ms, 3 = 4ms, 4 = 8ms, 5 = 16ms

A sliding window filter may be applied to the feedback. This is particularly useful in applications where the feedback is used to give speed feedback for the speed controller and where the load includes a high inertia, and so the speed controller gains are very high. Under these conditions, without a filter on the feedback, it is possible for the speed loop output to change constantly from one current limit to the other and lock the integral term of the speed controller.

It should be noted that if this filter is used where the speed feedback is provided by an EndAt or SSI encoder connected directly to the module, it is necessary for the encoder to provide at least 6 bits of turns information. This is not a problem when the position is defined by the absolute position from the encoder at initialisation and then accumulated delta positions (Pr x.16=0), however, if the absolute position is taken directly from the encoder (Pr x.16 > 0) the encoder must provide at least 6 bits of turns information. If this filter is not used (i.e. Pr x.19=0) turns information from the encoder is not required.

The speed filter can be used to reduce resolution "stepping" problems with low line per revolution encoder inputs when used through the feedback reference router also.

x.20		Maximum feedback reference					
RW	Uni						US
⇕	0.0 to 40,000.0rpm			⇒			
Update rate: Background read							

x.21		Feedback reference/ Motor thermistor resistance					
RO	Bi				NC	PT	
⇕	-100.0 to +100.00%			⇒			
Update rate: 4ms write							

The resistance value of the thermistor input can be seen in Pr x.21. The motor thermistor resistance value shown in Pr x.21 is shown in 0.1% of 10kΩ units. The position feedback when used as a reference can be viewed here.

x.22		Feedback reference scaling					
RW	Uni						US
⇕	0.000 to 4.000			⇒	1.000		
Update rate: Background read							

The feedback reference scaling is applied as follows:

3000rpm Motor							
Parameter		Example 1	Example 2	Example 3	Example 4	Example 5	Example 6
Pr x.20	Max f/b ref	3000.0	1500.0	6000.0	3000.0	1500.0	6000.0
Pr x.21	F/b ref	100.0	100.0	50.0	100.0	100.0	50.0
Pr x.22	F/b ref scaling	1.000	1.000	1.000	0.500	0.500	0.500
Pr x.23	Destination	Pr 1.21	Pr 1.21	Pr 1.21	Pr 1.21	Pr 1.21	Pr 1.21
Pr 1.21	Preset speed	3000.0	3000.0	1500.0	1500.0	1500.0	750.0

x.23		Feedback reference destination					
RW	Uni			DE			US
⇕	00.00 to 21.51			⇒	00.00		
Update rate: Read on reset							

The position feedback can be used as a reference for any unprotected parameter and is the output from the speed filter (Pr **x.19**). This value is also displayed in Pr **x.03** after further filtering to aid readability.

The filtered reference is converted to percentage of the maximum position feedback reference (Pr **x.20**) and displayed via the feedback reference (Pr **x.21**). This value is to the nearest tenth of a percent and is limited to $\pm 100.0\%$. The limited percentage value is then scaled by the feedback reference scaling (Pr **x.22**). This scaled value is also to the nearest tenth of a percent and is also limited to $\pm 100.0\%$. The value written to the destination parameter is converted to a percentage of the full-scale value of the destination (Pr **x.23**) to the nearest tenth of a percent.

The destination is updated every 4ms.

If the destination for the feedback is the hard speed reference (Pr **3.22**), a shortcut facility is provided in the drive. In order to invoke this facility, the maximum feedback reference (Pr **x.20**) must be set to the maximum currently used for the hard speed reference and the scaling parameter (Pr **x.22**) must be set to 1.0000. The destination is updated every 250 μ s and a value in rpm is written to Pr **3.22** every 4ms for indication only.

NOTE If the destination is default or invalid (non-existent or protected) Pr **x.21** displays the motor thermistor resistance in 0.1% of 10k Ω units. This operates even if Pr **x.12** (thermistor enable) is not enabled allowing the user to design their own characteristic without trips using the threshold detector.

Example

Speed is 200rpm Pr **x.20** is 400rpm so Pr **x.21** shows 50%. Pr **x.22** is 0.500 so the final percentage value is 25%. The destination is a 16 bit bipolar parameter which therefore will have $25\% * (2^{15}) = 8192$ written to it.

Effect of encoder resolution

A 1024 line encoder as the input produces 4096 counts per revolution. The resolution is one count per 250 μ s. As one count is 1/4096th of a revolution, the speed resolution is actually 58.8rpm.

A 4096 line encoder as the input produces 16384 counts per revolution. As one count is 1/16384th of a revolution, the speed resolution is actually 14.6rpm.

To compensate for the resolution of one count per 250 μ s the speed filter can be used. For example a filter of 4ms divides the resolution by 16, but could affect the performance of any control loop.

Effect of percentage resolution

Destinations other than the hard speed reference (Pr **3.22**) will be rounded to the nearest tenth of a percent. This would give a minimum resolution of 1 rpm if the destination maximum were 1000.0rpm for example.

x.24		Encoder simulation source							
RW	Uni							PT	US
↕	00.00 to 21.51			⇒	00.00				
Update rate: Read on reset									

x.25		Encoder simulation ratio numerator							
RW	Uni							US	
↕	0.0000 to 3.0000				⇒	0.2500			
Update rate: Background read									

The simulated encoder output (incremental), Ab, Ab.L, Fd, Fd.L can be scaled using the above parameter.

x.26		Encoder simulation ratio denominator							
RW	Uni							US	
↕	0.0000 to 3.0000				⇒	1.0000			
Update rate: Background read									

The simulated encoder output (incremental), Ab, Ab.L, Fd, Fd.L can be scaled using the above parameter.

x.27		Encoder simulation resolution select							
RW	Bit					NC		US	
↕	OFF (0) or On (1)				⇒	OFF (0)			
Update rate: Background read									

The simulated encoder output (incremental), Ab, Ab.L, Fd, Fd.L can be scaled using the above parameter.

An encoder simulation output can be generated from any parameter as a source as defined by Pr **x.24** (00.00 disables encoder simulation). Although any parameter can be used, the source parameter is assumed to be a 16 bit position value in the form of a roll-over counter. Therefore only parameters with a range of -32768 to 32767 or 0 to 65535 are normally used. The marker is simulated when the source rolls over or under.

The sources update rate should be considered when setting up a simulated encoder output, for example with Pr **x.05** as the source this has an update rate of 250µs (shortcut in software) with Pr **x.30** this has an update rate of 4ms (averaging is applied for the simulated encoder output in this example to prevent “stepping effects” being seen on the simulated encoder output.)

When the Solutions Module is connected to a high precision encoder (i.e. SinCos) and the source has been selected as the internal position (Pr **x.05**), the resolution can be increase to a 24 bit position value by setting Pr **x.27** to a one.

x.28		Encoder simulation mode							
RW	Txt							US	
↕	0 to 7				⇒	0			
Update rate: Background read									

Pr x.28 defines the output mode for simulated encoder output as follows.

Pr x.28	String	Mode
0	Ab	Quadrature
1	Fd	Frequency and direction
2	SSI.Gray	SSI output (Gray code)
3	SSI.Bin	SSI output (Binary format)
4	Ab.L	Quadrature with marker LOCK
5	Fd.L	Frequency and direction with marker LOCK
6	H.drv	Drive ABZ input signals routed through Hardware
7	H.int	Solutions Module ABZ input signals routed through Hardware

NOTE Modes 6 and 7 are only available with the drive software versions **01.07.00** onwards.

NOTE If the source is not the feedback device, the simulator waits until all feedback devices are initialised before the starting to output. The wait for initialisation does not occur if the drive software version is less than **V01.08.00**.

NOTE Also refer to section section 6.3 *Simulated encoder outputs* on page 45 for further detailed information.

x.29		Non-marker reset revolution counter							
RO	Uni					NC	PT		
↕	0 to 65535 revolutions				⇒				
Update rate: 4ms write									

x.30		Non-marker reset position							
RO	Uni					NC	PT		
↕	0 to 65535 (1/2 ¹⁶ ths of a revolution)				⇒				
Update rate: 4ms write									

x.31		Non-marker reset fine position							
RO	Uni					NC	PT		
↕	0 to 65535 (1/2 ³² nds of a revolution)				⇒				
Update rate: 4ms write									

This position is taken from the position feedback device and is not affected by the marker or the freeze inputs.

x.32		Marker revolution counter							
RO	Uni					NC	PT		
↕	0 to 65535 revolutions				⇒				
Update rate: 4ms write									

x.33		Marker position							
RO	Uni					NC	PT		
↕	0 to 65535 ($1/2^{16}$ ths of a revolution)				⇒				
Update rate: 4ms write									

x.34		Marker fine position							
RO	Uni					NC	PT		
↕	0 to 65535 ($1/2^{32}$ nds of a revolution)				⇒				
Update rate: 4ms write									

Each time the marker becomes active the non-marker position values (Pr **x.29** to Pr **x.31**) are sampled and stored in Pr **x.32** to Pr **x.34**.

x.35		Freeze revolution counter							
RO	Uni					NC	PT		
↕	0 to 65535 revolutions				⇒				
Update rate: 250µs write									

x.36		Freeze position							
RO	Uni					NC	PT		
↕	0 to 65535 ($1/2^{16}$ ths of a revolution)				⇒				
Update rate: 250µs write									

x.37		Freeze fine position							
RO	Uni					NC	PT		
↕	0 to 65535 ($1/2^{32}$ nds of a revolution)				⇒				
Update rate: 250µs write									

x.38		Freeze input mode/ Marker output select							
RW	Uni							US	
↕	0 to 7				⇒	1			
Update rate: Background read									

The freeze input to the SM Universal Encoder Plus can take the following forms

- A 485 signal through the encoder marker simulation output pins
- A 24V signal on the freeze 24V input
- A signal on the internal drive and slot freeze line generated by another Solutions Module.

The selection of which mode used is dependent on the value of Pr **x.38**. The default is 1 that corresponds to only the 24V input to this Solutions Module. The values correspond to the modes as described in the table below:

Value in Pr x.38	24V input	485 input	Drive/slot bus input
0	No	No	No
1	Yes	No	No
2	No	Yes	No
3	Yes	Yes	No
4	No	No	Yes
5	Yes	No	Yes
6	No	Yes	Yes
7	Yes	Yes	Yes

NOTE Modes 6 and 7 are only available with the drive software versions **01.07.00** onwards.

x.39		Freeze flag					
RW	Bit					NC	
↕		OFF (0) or On (1)			⇒	OFF (0)	
Update rate: 250µs write							

Each time the freeze input on the Solutions Module becomes active the non-marker position (Pr **x.29** to Pr **x.31**) is stored in Pr **x.35** to Pr **x.37** and the freeze flag (Pr **x.39**) is set. The freeze flag is not reset by the module and must be reset by the user. No other freeze conditions will be trapped if the flag is set.

x.40		Pass freeze to drive and other slots					
RW	Bit					NC	US
↕		OFF (0) or On (1)			⇒	OFF (0)	
Update rate: Background read							

This parameter enables the Solutions Module to pass the freeze signal internally to the drive and other slots so that when a freeze occurs on the Solutions Module the main drive position and/or other slots can also be frozen.

x.41		Freeze invert					
RW	Bit						US
↕		OFF (0) or On (1)			⇒	OFF (0)	
Update rate: Background read							

When Pr **x.41** = 0 freeze occurs on the rising edge of the freeze input. When Pr **x.41** = 1 freeze occurs on the falling edge of the freeze input.

x.42		Encoder comms transmit register/Sin signal value/commutation signal level							
RW	Uni					NC			
↕	0 to 65535				⇒	0			
Update rate: Background read									

In SINCOS mode (6) ONLY with no comms or commutation inputs, the internal differential Sin signal value is written to Pr **x.42** as an unsigned number. A value greater than 32768 in Pr **x.42** requires the user to minus 65536 to get the negative result. 0.675V approximate differential input produces 16384 (the maximum). The value given is quantized to 32 as the ADC produces a 10bit value with the outputs most significant bit in bit14 of the value in Pr **x.42**.

0.5V gives approximately 12192 and 0.25V gives approximately 6112.

In AB.Servo (3), FD.Servo (4) or FR.Servo (5) mode, the value in Pr **x.42** is obtained from the rules below. This permits the user to determine the current segment and status of the commutation inputs (U high equals logic 1, U low equals logic 0):

Pr **x.42** = 1000 * segment + 100 * U state + 10 * V state + W state

Example

If the commutation inputs equalled 110 (which is the 2nd segment) then {Pr **x.42** would be set to 2110.

Segment 9 means that the current commutation input is invalid.

All other modes follow the description for Pr **x.44**.

NOTE This parameter has no effect for SC.Servo encoders.

x.43		Encoder comms receive register/Cos signal value							
RW	Uni					NC			
↕	0 to 65535				⇒	0			
Update rate: Background write									

In SINCOS mode (6) ONLY with no comms or commutation inputs, the internal differential Cos signal is written to this parameter as an unsigned number.

A value greater than 32768 in Pr **x.43** requires the user to minus 65536 to get the negative result.

In AB.Servo (3), FD.Servo (4) or FR.Servo (5) mode, Pr **x.43** equals zero.

All other modes follow the description for Pr **x.44**.

NOTE This parameter has no effect for SC.Servo encoders.

x.44		Disable encoder position check							
RW	Bit					NC	PT		
↕	OFF (0) or On (1)				⇒	OFF (0)			
Update rate: Background read									

If Pr **x.44** is zero the drive can check the position derived with the sine and cosine waveforms from a SinCos encoder via serial communications.

If Pr **x.44** is set to one the checking is disabled and encoder comms is available via the

transmit and receive registers. The transmission system can be used to communicate with encoders provided the mode is either SC.HiPEr or SC.EndAt.

NOTE For further detailed information refer to Chapter 8 *Advanced Operation* on page 58.

x.45		Position feedback initialised							
RO	Bit						NC	PT	
↕					⇒				
Update rate: Background write									

At power-up Pr **x.45** is initially zero, but is set to one when the encoder connected to position module has been initialised. The drive cannot be enabled until this parameter is one.

If the encoder power-supply is lost, or the encoder type parameter is changed for an encoder connected to a Solutions Module, and the encoder type is SC, SC.HiPEr, SC.EndAt or EndAt the encoder will no longer be initialised. When an encoder is no longer initialised Pr **x.45** is reset to zero and the drive cannot be enabled. The encoder may be re-initialised, provided the drive is not active, by setting Pr **3.47** to one. Pr **x.45** is automatically reset to zero when the initialisation is complete.

x.46		Line per revolution divider							
RW	Uni							US	
↕		1 to 1024			⇒	1			
Update rate: Background read									

The LPR divider Pr **x.46** is used to scale the equivalent lines per revolution in Pr **x.10** of incremental and SinCos encoders, without comms, on rotary motors, and all but comms only encoders on linear motors. (Servo encoders must have the same number and pitch of poles as the motor.)

The equivalent line per revolution parameter (Pr **x.10**) is divided by the value in Pr **x.46**. This can be used when an encoder is used with a linear motor where the number of counts or sine waves per pole is not an integer.

Example

128.123 lines per revolution would be set as 128123 in Pr **x.10** and 1000 in Pr **x.46** giving:

$128123 / 1000 = 128.123$. If the value is less than 1, the value used will be 1.

When using SinCos encoders with comms, the comms and SinCos positions must be aligned. The comms position resolution may be a multiple of the analogue position resolution. When a linear encoder type has been selected (Pr **x.16** = 0) the value in Pr **x.09** is this multiple.

The motor pole pitch used to configure EndAt and Hiperface encoders is that of the currently selected motor map.

NOTE When setting larger values in Pr **x.10** when the Solutions Module is the main feedback device, the drive will limit the maximum speed, which in turn limits the maximum of some of the drive parameters such as Pr **1.06** and Pr **1.21**. If the overall value of the LPR after division is low once more, the parameters that have been limited will not return to their original values and may need to be increased. An ELPR of 10,000 gives a maximum speed of 3000rpm.

NOTE

When operating with an Incremental plus commutation (absolute encoder), Ab.Servo, Fd.Servo, Fr.Servo or SC.Servo this parameter should remain at default (Pr **x.46** = 1).

x.47		SSI output turns							
RW	Uni							US	
⇅	0 to 16				⇒	16			
Update rate: Background read									

Used to define the simulated encoder output in SSI mode, refer to Chapter 6.3 *Simulated encoder outputs* on page 45

x.48		SSI output comms resolution							
RW	Uni							US	
⇅	0 to 32 bits				⇒	0			
Update rate: Background read									

Used to define the simulated encoder output in SSI mode, refer to Chapter 6.3 *Simulated encoder outputs* on page 45

x.49		Lock position feedback							
RW	Bit								
⇅	OFF (0) or On (1)				⇒				
Update rate: Background write									

If Pr **x.49** is set to one, Pr **x.04**, Pr **x.05** and Pr **x.06** are not updated. If this parameter is zero, Pr **x.04**, Pr **x.05** and Pr **x.06** are updated normally.

x.50		Solutions Module error status							
RO	Uni					NC	PT		
⇅	0 to 255				⇒				
Update rate: Background write									

The error status is provided so that the only one option error trip is required for each Solutions Module slot. If an error occurs, the reason for the error is written to this parameter and the drive may produce a 'SLX.Er' trip, where x is the slot number. A value of zero indicates that the Solutions Module has not detected an error, a non-zero value indicates that an error has been detected. (See Chapter 10 *Diagnostics* for the meaning of the values in this parameter.) When the drive is reset, this parameter is cleared for the relevant Solutions Module.

This Solutions Module includes a temperature monitoring circuit. If the PCB temperature exceeds 90°C (94°C **V.03.02.00** or later), the drive fan is forced to operate at full speed (for a minimum of 10s). If the temperature falls below 90°C (94°C **V.03.02.00** or later), the fan can operate normally again. If the PCB temperature exceeds 100°C, the drive is tripped and the error status is set to 74.

x.51		Solutions Module software sub-version							
RO	Uni					NC	PT		
⇅	0 to 99				⇒				
Update rate: Write on power-up									

The SM-Universal Encoder Plus includes a processor with software. The software version is displayed in Pr **x.02** and Pr **x.51** in the form Pr **x.02** = xx.yy and Pr **x.51** = zz.

Where:

xx specifies a change that affects hardware compatibility

yy specifies a change that affects product documentation

zz specifies a change that does not affect the product documentation

When a Solutions Module is fitted that does not contain software, both Pr **x.02** and Pr **x.51** appear as zero.

NOTE

When operating with an Issue 3 SM-Universal Encoder Plus option module, the software must be **V.03.xx.xx**. When operating with an Issue 4 SM-Universal Encoder Plus option module, the software must be **V.04.xx.xx**

Failure to comply with the above can result in Solutions Module failure.

10 Diagnostics

10.1 Display

There are two keypads available for the Unidrive SP. The SM-Keypad has an LED display and the SM-Keypad Plus has an LCD display. Both keypads can be fitted to the drive but the SM-Keypad Plus can also be remotely mounted on an enclosure door.

10.1.1 SM-Keypad (LED)

The display consists of two horizontal rows of 7 segment LED displays.

The upper display shows the drive status or the current menu and parameter number being viewed.

The lower display shows the parameter value or the specific trip type.

Figure 10-1 SM-Keypad

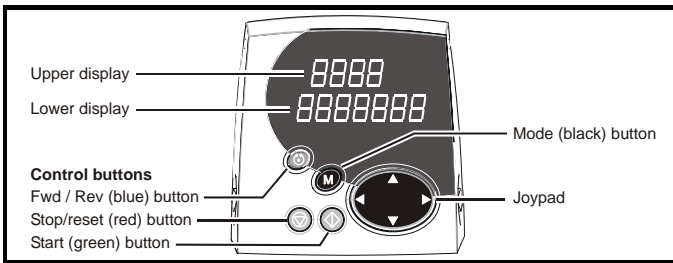

10.1.2 SM-Keypad Plus (LCD)

The display consists of three lines of text.

The top line shows the drive status or the current menu and parameter number being viewed on the left, and the parameter value or the specific trip type on the right.

The lower two lines show the parameter name or the help text.

Figure 10-2 SM-Keypad Plus

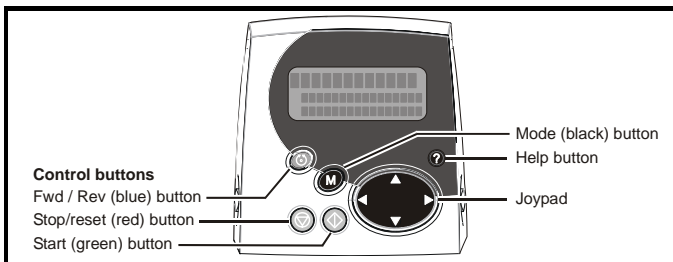

NOTE The red stop  button is also used to reset the drive.

If the drive trips, the output is disabled so that the drive stops controlling the motor. The lower display indicates that a trip has occurred and the upper display shows the trip. Trips are listed alphabetically in Table 10.3 based on the trip indication shown on the drive display. Refer to Figure 10-1.

If a display is not used, the drive LED Status indicator will flash if the drive has tripped. Refer to Figure 10-2.

The trip indication can be read in Pr **10.20** providing a trip number.

10.2 Displaying the trip history

The drive retains a log of the last 10 trips that have occurred in Pr **10.20** to Pr **10.29** and the corresponding time for each trip in Pr **10.43** to Pr **10.51**. The time of the trip is recorded from the powered-up clock (if Pr **6.28** = 0) or from the run time clock (if Pr **6.28** = 1).

Pr **10.20** is the most recent trip, or the current trip if the drive is in a trip condition (with the time of the trip stored in Pr **10.43**). Pr **10.29** is the oldest trip (with the time of the trip stored in Pr **10.51**). Each time a new trip occurs, all the parameters move down one, such that the current trip (and time) is stored in Pr **10.20** (and Pr **10.43**) and the oldest trip (and time) is lost out of the bottom of the log.

If any parameter between Pr **10.20** and Pr **10.29** inclusive is read by serial communications, then the trip number in Table 10.3 *Trip codes* on page 100 is the value transmitted.

Figure 10-1 Keypad status modes

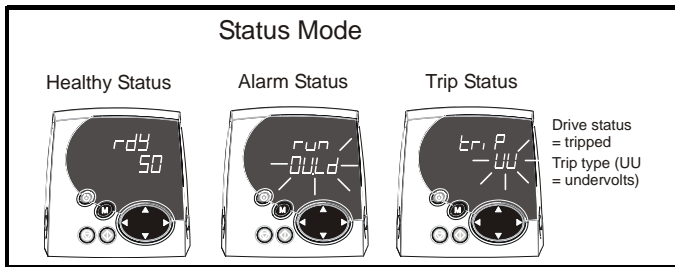
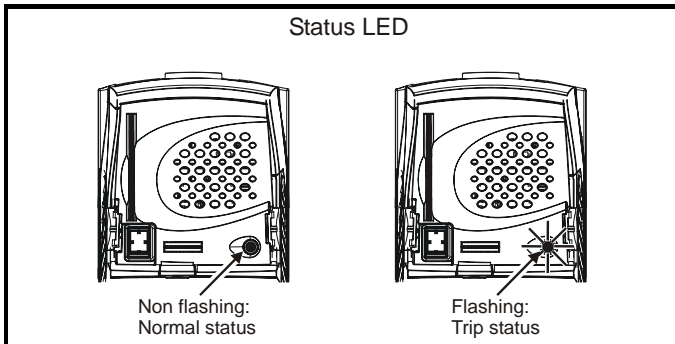

Figure 10-2 Location of the status LED



Any trip can be initiated by writing the relevant trip number to Pr **10.38**. If any trips shown as user trips are initiated the trip string is "txxx", where xxx is the trip number.

Trips can be reset after 1.0s if the cause of the trip has been rectified.

A full list of drive trips can be found in the *Unidrive SP User Guide*.

Table 10.3 Trip codes

Trip	Diagnosis
C.Optn	SMARTCARD trip: Solutions Modules fitted are different between source drive and destination drive
180	Ensure correct Solutions Modules are fitted Ensure Solutions Modules are in the same Solutions Module slot Press the red  reset button
Enc1	Drive encoder trip: Encoder power supply overload
189	Check encoder power supply wiring and encoder current requirement Maximum current = 200mA @ 15V or 300mA @ 8V and 5V
ENP.Er	Data error from electronic nameplate stored in selected position feedback device
178	Replace feedback device
PS.24V	24V internal power supply overload
9	The total user load of the drive and Solutions Modules has exceeded the internal 24V power supply limit. The user load consists of the drive's digital outputs plus the SM-I/O Plus digital outputs, or the drive's main encoder supply plus the SM-Universal Encoder Plus encoder supply. <ul style="list-style-type: none"> • Reduce load and reset • Provide an external 24V >50W power supply • Remove any Solutions Modules and reset
SLX.dF	Solutions Module slot X trip: Solutions Module type fitted in slot X changed
204, 209, 214	Save parameters and reset
SLX.HF	Solutions Module slot X trip: Solutions Module X hardware fault
200, 205, 210	Ensure Solutions Module is fitted correctly Return Solutions Module to supplier
SLX.nF	Solutions Module slot X trip: Solutions Module has been removed
203, 208, 213	Ensure Solutions Module is fitted correctly Replace Solutions Module Save parameters and reset drive
SLX.tO	Solutions Module slot X trip: Solutions Module watchdog time-out
201, 206, 211	Press reset. If the trip persists, contact the supplier of the drive.
SL.rtd	Solutions Module trip: Drive mode has changed and Solutions Module parameter routing is now incorrect
215	Press reset. If the trip persists, contact the supplier of the drive.

Trip	Diagnosis		
SLX.Er	Solutions Module slot X trip: Error detected with Solutions Module, where X is the slot number		
202, 207, 212	Pr x.50	Encoders	Fault description
	1	All	Power supply short circuit
	2	Ab.Fd, Fr, Ab.SERvo, Fd.SERvo, Fr.SERvo, SC.SERvo	+Hardware wire-break detect on A, B and Z inputs ⁽¹⁾
		SC, SC.HiPEr, SC.EndAt, SSC.SSI, SC.SERvo	Software wire break detection on sine wave signals
	3	Ab.SERvo, Fd.SERvo, Fr.SERvo, SC.SERvo	+Phase error ⁽²⁾
		SC.SERvo (both methods), SC.HiPEr, SC.EndAt, SC.SSI, SC.SERvo	+Sine/cosine phase error ⁽³⁾
	4	SC.HiPEr, SC.EndAt, SC.SSI	Comms failure (timeout)
		EndAt	Comms failure (timeout) or transfer time too long
		SSI	Comms transfer time is too long
	5	SC.HiPEr, SC.EndAt, EndAt	Checksum / CRC error or SSI not ready at start of position transfer (i.e. data input not one)
	6	SC.HiPEr, SC.EndAt, EndAt	The encoder has indicated an error
		SC.SSI, SSI	+Power supply failure
	7	SC, SC.HiPEr, SC.EndAt, SC.SSI, EndAt, SSI	Initialisation has failed due to a comms error.
	8	SC.HiPEr, SC.EndAt, EndAt	Auto-configuration has been requested by changing Pr x.18. An initialisation will occur to perform auto-configuration.
	9	All	Thermistor trip, Over-temperature
	10	All	Thermistor trip, Short circuit
	11	SC, SC.HiPEr, SC.EndAt, SC.SSI, SC.SERvo	Failure of analogue position alignment during encoder initialisation
	12	SC.HiPEr	The encoder type could not be identified during auto-configuration
	13	SC.EndAt, EndAt	The number of encoder turns read from the encoder during auto-configuration is not a power of 2
	14	SC.EndAt, EndAt	The number of bits defining the encoder position within a turn read from the encoder during auto-configuration is too large.
15	SC.HiPEr, SC.EndAt, EndAt	The number of periods per revolution is either less than 2 or greater than 50000 when read or calculated from the encoder data during auto-configuration.	
16	SC.EndAt, EndAt	The number of comms bits per period are larger than 255.	
74	All	The Solutions Module has overheated.	

+These trips can be enabled/disabled by Pr x.17

1. If the terminations are not enabled on the A, B or Z inputs the wire break system will not operate. (Note that as default the Z input terminations are disabled to disable wire break detection on this input.)
2. Phase error for a servo type encoder is to detect that the incremental pulses have been counted incorrectly. The error is detected if the incremental position moves by 10°C with respect to the position defined by the UVW commutation signals. The trip is initiated if the error is detected for 10 consecutive samples.
3. Phase error for SINCOS encoders with comms is detected by interrogating the encoder every second via comms to compare the incremental position determined from the sine waves with the incremental position via comms. If the error is $\leq 10 \times C$ for 10 consecutive samples the trip is initiated.

Encoder initialisation will occur when trips 1 to 8 are reset. This causes an encoder with comms to be re-initialised and auto-configuration to be performed if selected.

It is important that a break in the connections between the drive and the position feedback device can be detected. This feature is provided either directly or indirectly as listed.

When the drive is reset this parameter is cleared for the relevant Solutions Module

Wire-break detection

It may be important to detect a break in the connections between the drive and the position feedback device. This feature is provided for most encoder types either directly or indirectly as listed below.

Pr x.50	Encoders	Fault description
2	Ab, Fd, Fr, Ab.SERVO, Fd.SERVO, Fr.SERVO, SC.SERVO	Hardware detectors on the A(F), B(D,R) and Z signal detect a wire break.
2	SC, SC.HiPER, SC.EndAt, SC.SSI SC.SERVO	The differential levels of the sine and cosine waveforms are available to the drive, from this the drive detects wire break if $\text{Sine}^2 + \text{Cosine}^2$ are less than the value produced by two valid waveforms with a differential peak to peak magnitude of 0.25V (1/4 of the nominal level). This detects wire break in the sine and cosine connections.
4, 5	SC.HiPER, SC.EndAt, EndAt	Wire break in the comms link is detected by a CRC or timeout error.
5, 6	SSI	Wire break detection is difficult with these devices. However, if power supply monitoring is enabled the drive will be looking for a one at the start of the message and a zero to indicate that the power supply is okay. If the clock stops or the data line is disconnected the data input to the drive may stay in one state or the other and cause a trip.

10.3 Fault finding

There are various trip codes listed for the SM-Universal Encoder Plus, which identify faults present with the drive, option module, or encoder. Following is a guide on how to overcome some of the most common issues seen.

Issue	Cause	Solution
SLx.Er Pr x.50 = 2	Encoder wire break	Check encoder connections for wire break
SLx.Er Pr x.50 = 3	Phase error	Noise present on encoder feedback signals, check connections and screening. Incorrect connections of commutation signals.
SLx.Er Pr x.50 = 7	Initialisation has failed	Incorrect encoder supply voltage selected Pr x.13 Incorrect encoder number of lines Pr x.10
Enc 7	Initialisation failed	Drive encoder input Pr 3.38 is configured for a intelligent encoder SC.HiPEr, SC.EndAt, SC.SSI with no encoder connected. If no encoder fitted to drive encoder input set Pr 3.38 = 0, if encoder fitted checked connections and encoder setup.
SLx.Er Pr x.50 = 4	Comms failure	Check encoder comms connections Check encoder comms baud rate
SLx.Er Pr x.50 = 5	Checksum CRC error	Check encoder single turns comms resolution set-up in Pr x.11 . Check if using single turn absolute encoder that Pr x.09 used for set-up of multi-turn encoder is set to zero.
Enc 2	Encoder wire break	Disable drive encoder wire break detection if no encoder fitted with Pr 3.40 = 0
Enc 9	Position feedback selected	The position feedback for the drive configured in Pr 3.26 is incorrect.
Enc 10	Phase offset incorrect	Noise present on encoder feedback signals, check connections and screening. Incorrect number lines set-up Pr x.10 Wire break not enabled Pr x.17
Absolute position from absolute encoder incorrect at power up	Incremental signals reversed compared to Comms signals	If the incremental (SC) position is reversed compared to the comms position (EndAt) or at power up the drive will read the incorrect absolute comms position (comms position will increment in opposite direction to incremental position). Correct incremental signal connections.
Spurious operation OI.AC trips It.AC trips	Intermittent encoder connections	Check encoder connections to both option module and encoder at motor, enable wire break detection, Pr x.17 = 1
	Incorrect screen connections	Check encoder feedback signals with an oscilloscope (both differentially and to 0v) for induced noise. Ensure the screening recommendations are following recommendations in Section 4.5
	Loose / poor encoder mounting to motor	Check to ensure mechanical mounting of encoder is secure.
Maximum speed limited	Pr 1.06 value limited	Check parameter maximum in Section 11, page 130 of the Unidrive SP User Guide. If using the lines per revolution divider Pr x.46 and entering a large value into Pr x.10 , Pr 1.06 is automatically limited, this can however be increased to the limit detailed in the Unidrive SP User guide.
Freeze input / Marker output not functioning	Mode select Pr x.38	Ensure the correct mode is selected in Pr x.38
Revolution counter = zero	Turns in Pr x.09 not set-up correctly	This can either be setup automatically through auto configuration Pr x.18 (intelligent encoders only) or manually through Pr x.09 .

11 Terminal Data

For location of terminals refer to Figure 3-2 *SM-Universal Encoder Plus connectors* on page 8

11.1 Encoder inputs SK2

Ab, Fd, Fr, Ab.SERvo, Fd.SERvo, Fr.SERvo and SC.SERvo encoders

1	Channel A, Frequency or Forward
2	Channel A\, Frequency\ or Forward\
3	Channel B, Direction or Reverse
4	Channel B\, Direction\ or Reverse\
5	Marker pulse channel Z
6	Marker pulse channel Z\
7	Phase channel U
8	Phase channel U\
9	Phase channel V
10	Phase channel V\
11	Phase channel W
12	Phase channel W\
Type	EIA 485 differential receivers
Maximum frequency	600kHz
Line loading	<2 unit loads (for terminals 1 to 4) 32 unit loads (for terminals 5 and 6) 1 unit load (for terminals 7 to 12)
Line termination components	120Ω
Working common mode range	+12V to -7V
Absolute maximum applied voltage relative to 0V	+14V to -9 (u, v, w, z) ±25V (Ab, Fd, Fr)
Absolute maximum applied differential voltage	+14V to -9 (u, v, w, z) ±25V (Ab, Fd, Fr)

SC, SC.SERvo, SC.HiPEr, SC.EndAt and SC.SSI encoders

1	Channel Cos
2	Channel Cosref
3	Channel Sin
4	Channel Sinref
Type	Differential voltage
Maximum signal level	1.25V peak to peak
Maximum frequency	115kHz (250kHz with lower resolution. See Pr x.10 on page 79)
Maximum applied differential voltage	±1.5V

SC.HiPEr, SC.EndAt, EndAt, SSI and SC.SSI encoders

5	Data (input)
6	Data\ (input)
11	Clock (input)***
12	Clock\ (input)***
Type	EIA 485 differential transceivers
Maximum frequency	2MHz
Line loading	32 unit loads (for terminals 5 and 6) 1 unit load (for terminals 11 and 12)
Working common mode range	+12V to -7V
Absolute maximum applied voltage relative to 0V	±14V
Absolute maximum applied differential voltage	±14V

*** Not used with SC.HiPEr encoders.

11.2 Simulated encoder outputs SK2

Simulated Ab, Fd encoder outputs (software simulation and hardware)

7	Frequency F, Quadrature A
8	Frequency F\, Quadrature A\
9	Frequency D, Quadrature B
10	Frequency D\, Quadrature B\
Type	EIA 485 differential receivers
Maximum frequency	500kHz
Line loading	<2 unit loads (for terminals 1 to 4) 32 unit loads (for terminals 5 and 6) 1 unit load (for terminals 7 to 12)
Line termination components	120Ω
Working common mode range	+12V to -7V
Absolute maximum applied voltage relative to 0V	±14V
Absolute maximum applied differential voltage	±14V

NOTE

The simulated encoder outputs available on terminal PL1 are identical to the simulated encoder outputs available on terminal SK2 (internally connected)

Simulated SSI encoder output (Binary or Graycode)

7	Data (output)	
8	Data\ (output)	
9	Clock\ (input)	
10	Clock (input)	
Type	EIA 485 differential transceivers	
Maximum frequency	Limited to 500kHz (output frequency set by master)	
Line loading	32 unit loads (for terminals 5 and 6) 1 unit load (for terminals 11 and 12)	
Working common mode range	+12V to -7V	
Absolute maximum applied voltage relative to 0V	±14V	
Absolute maximum applied differential voltage	±14V	

11.3 Drive encoder power supply

Common to all Encoder types

13	Encoder supply voltage	
Supply voltage	5V, 8V or 15V	
Maximum output current	300mA for 5V and 8V 200mA for 15V	

The encoder supply voltage is controlled by Pr **x.13**. The default for this parameter is 5V (0) but this can be set to 8V (1) or 15V (2). Setting the encoder voltage supply too high for the encoder could result in damage to the feedback device.

The termination resistors should be disabled if the outputs from the encoder are higher than 5V.

14	0V common	
-----------	------------------	--

15	Motor thermistor input	
Short circuit trip level	<50Ω ±30%	
Over temperature trip level	<3k3Ω ±10%	
Reset level	>3k3Ω	

11.4 Encoder inputs PL1

Ab, Fd, Fr, Ab.SErvo, Fd.SErvo, Fr.SErvo, SC, SC.HiPEr, SC.EndAt, SC.SSI and SC.SErvo encoders

1	+24V freeze
8	RS485 freeze
9	RS485\ freeze
Type	EIA 485 differential receivers
Maximum frequency	600kHz
Line loading	<2 unit loads (for terminals 1 to 4) 32 unit loads (for terminals 5 and 6) 1 unit load (for terminals 7 to 12)
Line termination components	120Ω
Working common mode range	+12V to -7V
Absolute maximum applied voltage relative to 0V	±25V
Absolute maximum applied differential voltage	±25V

NOTE The freeze input function is not available with EndAt only and SSI only encoders

11.5 Encoder outputs PL1

Simulated Ab, Fd encoder output (software simulation and hardware)

3	Channel A frequency F
4	Channel A\ frequency F\
5	Channel B direction D
6	Channel B\ direction D\
8	Marker pulse Z
9	Marker pulse Z\
Type	EIA 485 differential receivers
Maximum frequency	500kHz
Line loading	<2 unit loads (for terminals 1 to 4) 32 unit loads (for terminals 5 and 6) 1 unit load (for terminals 7 to 12)
Line termination components	120Ω
Working common mode range	+12V to -7V
Absolute maximum applied voltage relative to 0V	±25V
Absolute maximum applied differential voltage	±25V

Simulated SSI encoder output (Binary or Graycode)

3	Data (output)
4	Data\ (output)
5	Clock\ (input)
6	Clock (input)
Type	EIA 485 differential transceivers
Maximum frequency	Limited to 500kHz (output frequency set by master)
Line loading	32 unit loads (for terminals 5 and 6) 1 unit load (for terminals 11 and 12)
Working common mode range	+12V to -7V
Absolute maximum applied voltage relative to 0V	±14V
Absolute maximum applied differential voltage	±14V

NOTE

The simulated encoder outputs available on terminal PL1 are identical to the simulated encoder outputs available on terminal SK2 (internally connected)

Index

B	
Baud rate	69
C	
Cable length	68, 69
Cautions	6
Clock	49
Colour coding	8
Commutation signals	12
Compatible with encoder types	9
Compliance	7
D	
Data transfer	50
Data transferral via comms	65
Diagnostics	98
Drive encoder power supply	106
E	
Electrical noise	26, 37
Electrical safety	6
Electronic nameplate transfers	66
EMC	29
Encoder circuit with galvanic isolation from encoder body	33
Encoder comms baud rate	64
Encoder inputs PL1	107
Encoder inputs SK2	104
Encoder outputs PL1	107
Encoder simulation resolution	90
Encoder transmit	58
Encoder type	82
Encoder with galvanic isolation from motor	33
EndAt comms	65
EndAt encoder	38
EndAt encoder comms baud rate	64
Environmental limits	7
Error detection level	86
Error status	96
F	
Features	8
Feedback cable	35
Feedback cable connections	36
Feedback filter	87
Feedback reference	88
Flux alignment test	16
Freeze data	53
Freeze flag	53
Freeze input mode	92
Freeze input with SM-Applications option module	53

Freeze inputs	52
G	
Galvanic isolation	32, 33
Ground clamps	35
Grounding bracket	30
Grounding clamp	29
H	
Hiperface encoders	38
I	
Incremental encoders	9, 39
Incremental plus commutation	12
Incremental plus commutation, Absolute encoders	40
Initialisation	14
Installation	37
K	
Keypad status modes	99
L	
Limitations	10
Line loading - PL1	107, 108
Line loading - SK2	104, 105, 106
Line per revolution divider	95
Lines per revolution divider	43
Loading object parameters	66
Logic diagram	74
M	
Marker data	51
Marker flag	51
Marker inputs	51
Maximum frequency - PL1	107, 108
Maximum frequency - SK2	104, 105, 106
Maximum output current - drive encoder power supply	106
Maximum signal level - SK2	104
Maximum voltage - PL1	107, 108
Maximum voltage - SK2	105, 106
Module identification	8
N	
No Isolation	34
No isolation	35
Non marker data	51
O	
Option ID code	76
Output initialisation	45
P	
Parameter - single line descriptions	71
Parameter coding	70
Parameter descriptions	76
Parameter structure	70

Parameters - adjusting	7
Parameters - motor object	67
Parameters - performance object	68
Performance object	68
Power cables	36
Power supply overload	100
R	
Resolution	22
S	
Safety of personnel	6
SC.EndAt	61
SC.EndAt positional data transfer	62
SC.HiPEr	59
SC.HiPEr positional data transfer	60
SECURE DISABLE	6
Serial communications	58
Set-up parameters	9
Shield connections	28, 35
Simulated encoder output resolution	47
Simulated encoder output SSI	48
Simulated encoder outputs	45
Simulated encoder outputs SK2	105
Simulated marker outputs	51
SinCos	58
SinCos encoder comms baud rate	58
SinCos encoder feedback signals	10
SM-Keypad	98
SM-Keypad Plus	98
Software simulation - high resolution encoder	47
Software version	76
Solutions Module identification	8
SSI - EndAt	64
SSI comms	66
SSI encoder comms baud rate	64
Storing object parameters	66
T	
Temperature monitoring circuit	96
Termination - PL1	107
Termination - SK2	104, 105
Termination resistors	43
Thermistor input	55
Transmission delays	68
Trip history	99
W	
Warnings	6
Wire break detect	84



SCIGATE AUTOMATION (S) PTE LTD

No.1 Bukit Batok Street 22 #01-01 Singapore 659592

Tel: (65) 6561 0488

Fax: (65) 6562 0588

Email: sales@scigate.com.sg

Web: www.scigate.com.sg

Business Hours: Monday - Friday 8.30am - 6.15pm



0471-0005-06